



User Manual

[Administrator Operations]

The essentials of Imaging

www.minolta.com

CF2002/CF3102

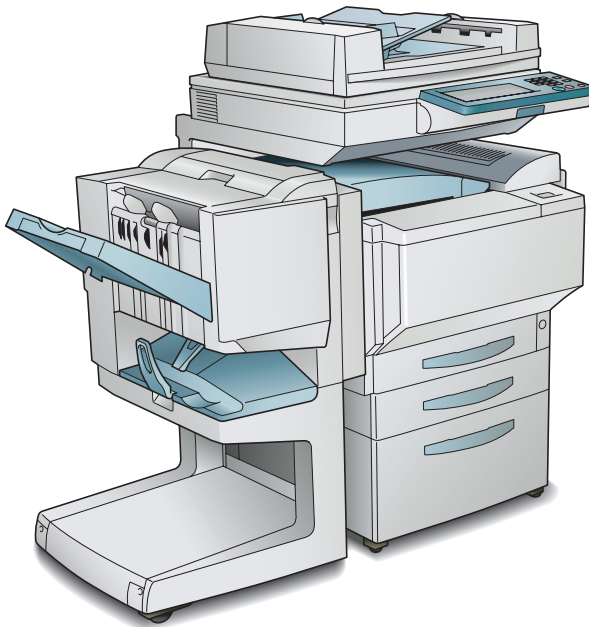

1

Read First

- Introduction
- Safety Information
- Precautions
- Part Names and Their Functions
- Utility Mode Operations
- Touch Panel Messages
- Troubleshooting
- Appendix



DiALTA Color

Contents

The topics listed below are described in the “Administrator Operations” volume. For details on other topics, refer to the Basic Operations and the Advanced Operations volumes of the User Manual and the Enlarge Display Mode Operation Guide.

1 Introduction

1.1	Introduction	1-2
	Structure of the Manual	1-2
1.2	Explanation of Manual Conventions	1-3
1.3	Explanation of Basic Concepts and Symbols	1-4
	Paper Feeding	1-4
	“Width” and “Length”	1-5
	Paper Orientation	1-5
	Portrait and Landscape	1-5
	Display Icons	1-6
	Paper Supply Icons	1-6
1.4	Energy Star®	1-7
	What is an ENERGY STAR® Product?	1-7
1.5	Trademarks and Registered Trademarks	1-7

2 Safety Information

2.1	Warning and Precaution Symbols	2-2
2.2	Meaning of Symbols	2-2
	WARNING	2-3
	CAUTION	2-4
2.3	Precautions for Routine Use	2-5
2.4	USER INSTRUCTIONS	2-5
	FCC PART 15 - RADIO FREQUENCY DEVICES (For U.S.A. Users)	2-5
2.5	INTERFERENCE-CAUSING EQUIPMENT STANDARD	2-6
	(ICES-003 IS-SUE 3) (For Canada Users)	2-6
2.6	For Users in countries not subject to Class B regulations	2-6
2.7	LED Radiation Safety	2-6
2.8	Ozone Release	2-6

3 Precautions

- 3.1 Installation Precautions 3-2**
 - Installation Site 3-2
 - Power Source 3-2
 - Space Requirements 3-3
- 3.2 Operation Precautions 3-4**
 - Operating environment 3-4
 - Proper use 3-4
 - Transporting the copier 3-5
 - Care of copier supplies 3-5
 - Storage of copies 3-6
- 3.3 Legal Restrictions on Copying 3-7**

4 Part Names and Their Functions

- 4.1 Components and Their Functions 4-2**
- 4.2 Parts Names and Their Functions 4-5**
 - Outside of Copier 4-5
 - Supplies and Parts 4-8
 - Inside of Copier 4-9
 - Options 4-10

5 Utility Mode Operations

- 5.1 Utility Screen 5-2**
 - Specifying the Input Screen Functions 5-3
 - Specifying the Initial Mode Settings (“Reset Mode” Function) 5-4
 - To specify the initial mode settings 5-4
 - Using Copy Programs 5-5
 - To store a copy program 5-5
 - To recall a stored copy program and use it to make copies 5-6
- 5.2 Specifying Default Settings (“User’s Choice” Functions) 5-7**
 - User’s Choice: 1 Screens 5-7
 - User’s Choice: 2 Screens 5-9
 - To set the “Confirmation Beep” function 5-10
 - To set the “Date/Time Set” function 5-11
 - To set the “Memory Recall” function 5-13
 - To set the “Key Repeat Start Time/Interval” function 5-15
 - To set the “Auto Panel Reset” function 5-16
 - To set the “Energy Saver” function 5-17
 - To set the “Sleep” function 5-18
 - To set the “Auto Clear Mode” function 5-19
 - To set the “Enlarge-Display Notice” function 5-20
 - “Specialty Paper” Settings 5-21

To set the “Specialty Paper” function	5-22
Specifying the Output Tray Priority	5-23
To set the “Priority exit tray” function	5-23
To set the “Intelligent Sorting” function	5-24
To set the “Criss Cross Mode” function.....	5-25
To set the “Priority Device” function	5-26
To set the “ACS Judgement Level Adjust.” function	5-27
To set the “2in1, 4in1, Booklet Copy Zoom” function	5-28
To set the “Auto-select Paper for Small Original” function	5-29
To set the “4in1 Copy Order” function.....	5-30
To set the “Centering” function.....	5-31
5.3 Viewing Counters (“Meter Count” Function).....	5-32
5.4 Viewing Part Maintenance Levels (“Unit life indicator” Function).....	5-34
5.5 Administrator Mode Operations	5-35
To set the “Top Erase” function.....	5-36
To set the “Disable Sleep Mode” function	5-37
To set the “over size paper selection” function	5-38
To set the “Language Selected” function	5-39
Specifying Expert Mode functions	5-40
To set the “Thick Paper and OHP Film Image Density” function.....	5-41
To adjust the color shifts manually.....	5-42
To set the “Monochrome Image density correct” function.....	5-46
To set the “Stabilizer” function	5-47
Setting the “PRT Area” Functions	5-47
To set the “PRT Area (Top Margin)” function	5-47
To set the “PRT Area (Left Margin)” function	5-50
To set the “PRT Area (Dup. Left Margin)” function	5-52
To set the “Center Binding Position” function.....	5-54
To set the “Gradation Adjust” function	5-56
To set the “Stabilizer” function (if the image is still incorrect, even after the gradation levels have been adjusted).....	5-58
5.6 Supervising Copier Use (Copy Track Functions)	5-60
Setting the Copy Track Functions	5-60
Specifying Account Settings.....	5-63
To set the “Copy Track Mode” parameter	5-63
To print a “Copy Track Data” counter.....	5-66
To initialize a “Copy Track Mode” counter	5-67
To specify settings for a “Copy Track Data” counter.....	5-69
To specify permissions for an account.....	5-71
To apply the specified limits	5-73

6 Touch Panel Messages

6.1	When the Message “CF Toner Cartridge (X) needs to be replaced soon.” Appears	6-2
	Display in Enlarge Display Mode	6-2
6.2	When the Message “Replace the CF Toner cartridge” Appears	6-3
	Display in Enlarge Display Mode	6-3
	To replace the toner cartridge	6-5
6.3	When the Message “Replace Staple Cartridge.” Appears	6-9
	Display in Enlarge Display Mode	6-9
	To replace the staple cartridge for FN-116.....	6-10
	To replace the staple cartridge for FN-8.....	6-12
6.4	When the Message “Misfeed detected.” Appears	6-17
	Locations of Paper Misfeeds	6-17
	Locations of Paper Misfeeds in the Enlarge Display Mode	6-17
	To clear a paper misfeed in the manual bypass tray.....	6-19
	To clear a paper misfeed in the duplex unit.....	6-21
	To clear a paper misfeed in a paper drawer.....	6-22
	To clear a paper misfeed in the large capacity cabinet	6-24
	To clear a paper misfeed in the right-side door	6-25
	To clear a paper misfeed in the upper right-side door.....	6-28
	To clear a paper misfeed in the duplexing document feeder.....	6-31
	To clear a paper misfeed in finisher FN-116	6-35
	To clear a paper misfeed in finisher FN-8	6-39
6.5	When the Message “Staple mode cannot be used.” Appears	6-43
	To clear jammed staples in FN-116.....	6-43
	To clear jammed staples in FN-8.....	6-45
6.6	When the Message “Remove Punch scraps.” Appears	6-51
	Display in Enlarge Display Mode	6-51
	To empty the hole-punch waste container.....	6-52
6.7	When the Inspection Mark “” Appears	6-53
	Display in Enlarge Display Mode	6-53
	Display in Enlarge Display Mode	6-54
6.8	When the Message “Malfunction detected.” Appears	6-55
	Display in Enlarge Display Mode	6-55
6.9	When the Message “XXXX needs to be replaced soon.” Appears	6-56
	Display in Enlarge Display Mode	6-56

6.10	When the Message “Replace XXXX.” Appears	6-57
	Display in Enlarge Display Mode	6-57
6.11	Other Messages	6-58
7	Troubleshooting	
7.1	When the Print Quality Is Low	7-2
7.2	When the Copier Is Not Operating Correctly	7-5
8	Appendix	
8.1	Specifications	8-2
	Copier CF2002/CF3102	8-2
	Duplex Unit AD-14	8-3
	Duplexing Document Feeder AFR-18	8-4
	Table 1: Possible combinations for mixed original paper sizes.....	8-4
	Paper Feed Unit PF-118	8-5
	Large Capacity Cabinet PF-121	8-5
	Finisher FN-8	8-5
	Finisher FN-116	8-6
	Option Tray	8-7
8.2	Care of the Copier	8-8
	Cleaning	8-8
	Housing cover	8-8
	Original glass	8-8
	Operation panel.....	8-9
	Document transfer belt.....	8-9
	Paper take-up roller.....	8-10
	Electrostatic charger	8-10
8.3	Function Combination Table	8-11
	Function Combination Table	8-17
8.4	Paper Size and Zoom Ratio Tables	8-19
	Paper Sizes	8-19
	Zoom Ratios.....	8-20
8.5	Consumables	8-23
	Paper.....	8-23
	Toner Cartridges	8-23
	Staple Cartridges	8-24
9	Index	
9.1	Index	9-2

Basic Operations

For details on the following topics, refer to the “Basic Operations” volume of this User Manual.

- 1 Before Making Copies**
- 2 Basic Copy Operations**
- 3 Loading Paper**
- 4 Original Documents**
- 5 Specifying Copy Settings**
- 6 Controlling Jobs**

Advanced Operations

For details on the following topics, refer to the “Advanced Operations” volume of this User Manual.

Available Features

- 1 Auxiliary Functions**
- 2 Scanning Operations**

Enlarge Display Mode Operation Guide

For details on the following topics, refer to the Enlarge Display Mode Operation Guide.

- 1 Before Making Copies**
- 2 Basic Copy Operations**
- 3 Copy Paper**
- 4 Original Documents**
- 5 Specifying Copy Settings**
- 6 Job List**

Introduction

1

1.1 Introduction

Structure of the Manual

The various explanations for this copier are divided into four parts: the Administrator Operations, Basic Operations and Advanced Operations volumes of the User Manual, and the Enlarge Display Mode Operation Guide.

The Administrator Operations volume of this User Manual contains precautions on the use of this copier. Be sure to read this volume before using the machine. The Basic Operations and Advanced Operations volumes of the User Manual and Enlarge Display Mode Operation Guide contain information on the many functions available. After reading the User Manual, be sure to store it in a safe place for future reference.

- **Administrator Operations**
This volume provides precautions for using the machine, descriptions on functions for use by the administrator (Utility Mode and Administrator Mode functions), procedures for replacing parts and supplies, troubleshooting procedures and machine specifications. Before using the copier, be sure to read chapters 1 through 4 of the Administrator Operations volume.
- **Basic Operations**
This volume contains precautions for using the machine and descriptions on the procedures for basic operations. The Basic Operations volume is a quick reference for immediate use of the copier.
- **Advanced Operations**
This volume includes descriptions on the Auxiliary functions in addition to precautions for the use of the copier. Read the Advanced Operations volume for more information on the various functions that this copier provides for any need.
- **Enlarge Display Mode Operation Guide**
This guide provides descriptions on the operations available in the Enlarge Display mode.
In the Enlarge Display mode, the controls for frequently used functions are enlarged, making them easier to read.
The Basic Operations volume of the User Manual contains details on the operation of the various functions. When using the Enlarge Display mode, first read the Basic Operations volume before referring to the Enlarge Display Mode Operation Guide.

1.2 Explanation of Manual Conventions

The marks and text formats used in this manual are described below.



WARNING

Failure to observe instructions highlighted in this manner may result in fatal or critical injuries.

→ Observe all warnings in order to ensure safe use of the copier.



CAUTION

Failure to observe instructions highlighted in this manner may result in serious injuries or property damage.

→ Observe all cautions in order to ensure safe use of the copier.



Note*

(*May also appear as "Important" or "Tip")

Text highlighted in this manner contains useful information and tips to ensure safe use of the copier.

1 The number 1 as formatted here indicates the first step of a sequence of actions.

2 Subsequent numbers as formatted here indicate subsequent steps of a sequence of actions.

? *Text formatted in this style provides additional assistance.*

→ Text formatted in this style describes the action that will ensure the desired results are achieved.

An illustration inserted here shows what operations must be performed.

[Copy] key

The names of keys on the control panel are written as shown above.

1.3 Explanation of Basic Concepts and Symbols

The use of words and symbols in this manual are explained below.

Paper Feeding

During printing, paper is supplied from the right side of the copier and fed into the output tray on top or the output option at the left with the printed surface of the page facing down. The paper feed direction is shown by the arrows in the diagram below.

During copying, paper is supplied from the right side of the copier and fed into the copy tray on the top or the output option at the left with the printed surface of the copy facing down. The paper feed direction is shown by the arrows in the diagram below.

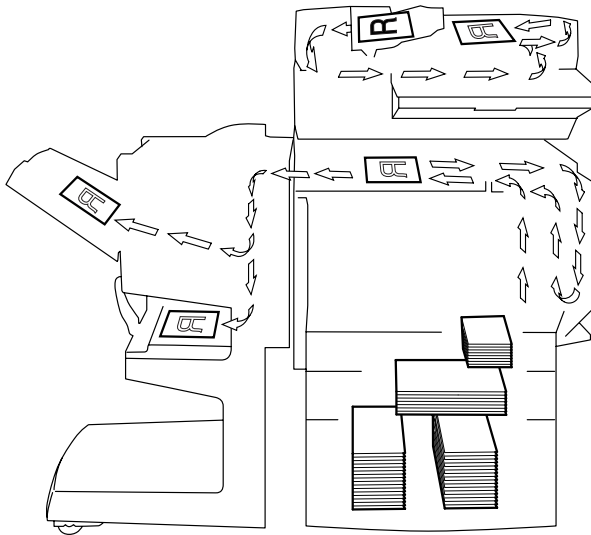

“Width” and “Length”

Whenever paper dimensions are mentioned in this manual, the first value always refers to the width of the paper (shown as “Y” in the illustration) and the second to the length (shown as “X”).

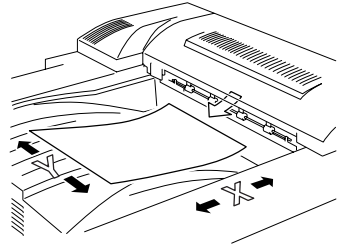
**Paper Orientation**

Lengthwise ()

If the width (Y) of the paper is shorter than the length (X), the paper has a vertical or portrait orientation, indicated by either “L” or .

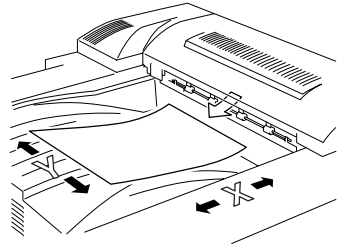

Crosswise ()

If the width (Y) of the paper is longer than the length (X), the paper has a horizontal or landscape orientation, indicated by either “C” or .

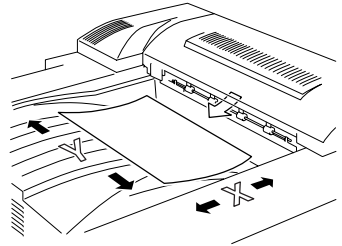
**Portrait and Landscape**

Portrait



With the “portrait” orientation, the paper is vertical, like a portrait.

Landscape



With the “landscape” orientation, the paper is horizontal, like a landscape.

Display Icons



Overhead projector transparencies



Envelope



Thick paper 1



Thick paper 2



Thick paper 3



Second side of a double-sided copy on plain paper



Second side of a double-sided copy on thick paper 1



Second side of a double-sided copy on thick paper 2



Second side of a double-sided copy on thick paper 3

Paper Supply Icons

The icons shown below are displayed to indicate the amount of paper that remains.

The paper is low.



The paper is empty.



1.4 Energy Star®



As an ENERGY STAR® Partner, we have determined that this machine meets the ENERGY STAR® Guidelines for energy efficiency.

What is an ENERGY STAR® Product?

An ENERGY STAR® product has a special feature that allows it to automatically switch to a “low-power mode” after a period of inactivity. An ENERGY STAR® product uses energy more efficiently, saves you money on utility bills and helps protect the environment.

1.5 Trademarks and Registered Trademarks

DiALTA is a registered trademark of Minolta Co., Ltd.

All other product names mentioned are trademarks or registered trademarks of their respective companies

***Safety
Information***

2



This section contains detailed instructions on the operation and maintenance of this machine. To achieve optimum utility of this device, all operators should carefully read and follow the instructions in this manual. Please keep this manual in a handy place near the machine.

Please read the next section before using this device. It contains important information related to user safety and preventing equipment problems.

Make sure you observe all of the precautions listed in this manual.

* Please note that some parts of the contents of this section may not correspond with the purchased product.

2.1 Warning and Precaution Symbols

 WARNING:	Ignoring this warning could cause serious injury or even death.
 CAUTION:	Ignoring this caution could cause injury or damage to property.

2.2 Meaning of Symbols



A triangle indicates a danger against which you should take precaution.



This symbol warns against cause burns.



A diagonal line indicates a prohibited course of action.



This symbol warns against dismantling the device.











A black circle indicates an imperative course of action.



This symbol indicates you must unplug the device.

 **WARNING**

	<ul style="list-style-type: none"> Do not modify this product, as a fire, electrical shock, or breakdown could result. If the product employs a laser, the laser beam source could cause blindness. Do not attempt to remove the covers and panels which have been fixed to the product. Some products have a high-voltage part or a laser beam source inside that could cause an electrical shock or blindness.
	<ul style="list-style-type: none"> Only use the power cord supplied in the package. Failure to use this cord could result in a fire or electrical shock. Do not use the power cord for this copier with any other product. Using this copier's power cord with another product could result in fire or an electric shock. Use only the specified power source voltage. Failure to do that could result in a fire or electrical shock. Do not use a multiple outlet adapter to connect any other appliances or machines. Use of a power outlet for more than the marked current value could result in a fire or electrical shock.
	<p>Do not unplug and plug in the power cord with a wet hand, as an electrical shock could result.</p>
	<p>Plug the power cord all the way into the power outlet. Failure to do this could result in a fire or electrical shock.</p>
	<ul style="list-style-type: none"> Do not scratch, abrade, place a heavy object on, heat, twist, bend, pull on, or damage the power cord. Use of a damaged power cord (exposed core wire, broken wire, etc.) could result in a fire or breakdown. Should any of these conditions be found, immediately turn OFF the power switch, unplug the power cord from the power outlet, and then call your authorized service representative. Do not use an extension cord, in principle. Use of an extension cord could cause a fire or electrical shock. Contact your authorized service representative if an extension cord is required.
	<p>Do not place a flower vase or other container that contains water, or metal clips or other small metallic objects on this product. Spilled water or metallic objects dropped inside the product could result in a fire, electrical shock, or breakdown. Should a piece of metal, water, or any other similar foreign matter get inside the product, immediately turn OFF the power switch, unplug the power cord from the power outlet, and then call your authorized service representative.</p>
	<ul style="list-style-type: none"> Do not keep using this product, if this product becomes inordinately hot or emits smoke, or unusual odor or noise. Immediately turn OFF the power switch, unplug the power cord from the power outlet, and then call your authorized service representative. If you keep on using it as is, a fire or electrical shock could result. Do not keep using this product, if this product has been dropped or its cover damaged. Immediately turn OFF the power switch, unplug the power cord from the power outlet, and then call your authorized service representative. If you keep on using it as is, a fire or electrical shock could result.
	<p>Do not throw the toner cartridge or toner into an open flame. The hot toner may scatter and cause burns or other damage.</p>
	<p>Connect the power cord to an electrical outlet that is equipped with a grounding terminal.</p>

 **CAUTION**

- Do not use flammable sprays, liquids, or gases near this product, as a fire could result.
- Do not leave a toner unit or drum unit in a place within easy reach of children. Licking or ingesting any of these things could injure your health.
- Do not let any object plug the ventilation holes of this product. Heat could accumulate inside the product, resulting in a fire or malfunction.
- Do not install this product at a site that is exposed to direct sunlight, or near an air conditioner or heating apparatus. The resultant temperature changes inside the product could cause a malfunction, fire, or electrical shock.
- Do not place the product in a dusty place, or a site exposed to soot or steam, near a kitchen table, bath, or a humidifier. A fire, electrical shock, or breakdown could result.
- Do not place this product on an unstable or tilted bench, or in a location subject to a lot of vibration and shock. It could drop or fall, causing personal injury or mechanical breakdown.
- After installing this product, mount it on a secure base. If the unit moves or falls, it may cause personal injury.
- Do not store toner units and PC drum units near a floppy disk or watch that are susceptible to magnetism. They could cause these products to malfunction.



The inside of this product has areas subject to high temperature, which may cause burns. When checking the inside of the unit for malfunctions such as a paper misfeed, do not touch the locations (around the fusing unit, etc.) which are indicated by a "Caution! High Temperature!" warning label.



Do not place any objects around the power plug as the power plug may be difficult to pull out when an emergency occurs.



The socket-outlet shall be installed near the machine and shall be easily accessible as the power plug may be difficult to pull out when an emergency occurs.



- Always use this product in a well ventilated location. Operating the product in a poorly ventilated room for an extended period of time could injure your health. Ventilate the room at regular intervals.
- Whenever moving this product, be sure to disconnect the power cord and other cables. Failure to do this could damage the cord or cable, resulting in a fire, electrical shock, or breakdown.
- When moving this product, always hold it by the locations specified in the User manual or other documents. If the unit falls it may cause severe personal injury. The product may also be damaged or malfunction.
- Remove the power plug from the outlet more than one time a year and clean the area between the plug terminals. Dust that accumulates between the plug terminals may cause a fire.
- When unplugging the power cord, be sure to hold onto the plug. Pulling on the power cord could damage the cord, resulting in a fire or electrical shock.

2.3 Precautions for Routine Use

	<ul style="list-style-type: none"> Do not store toner units, PC drum units, and other supplies and consumables in a place subject to direct sunlight and high temperature and humidity, as poor image quality and malfunction could result. Do not attempt to replace the toner unit and PC drum unit in a place exposed to direct sunlight. If the PC drum is exposed to intense light, poor image quality could result. Do not unpack a toner unit or PC drum unit until the very time of use. Do not leave an unpacked unit standing. Install it immediately or poor image quality could result. Do not keep toner units and PC drum units in an upright position or upside down, as poor image quality could result. Do not throw or drop a toner unit or PC drum unit as poor image quality could result. Do not use this product in an area where ammonia or other gases or chemicals are present. Failure to do so may shorten the service life of the product, cause damage or decrease performance. Do not use this product in an environment with a temperature outside the range specified in the User manual, as a breakdown or malfunction could result. Do not attempt to feed stapled paper, carbon paper or aluminum foil through this product, as a malfunction or fire could result.
	Do not touch or scratch the surface of the toner unit, developing roller and the PC drum, as poor image quality could result.
	Use the supplies and consumables recommended by the dealer. Use of any supply or consumable not recommended could result in poor image quality and breakdown.

2.4 USER INSTRUCTIONS

FCC PART 15 - RADIO FREQUENCY DEVICES (For U.S.A. Users)

NOTE: This equipment has been tested and found to comply with the limits for a Class A digital device, pursuant to Part 15 of the FCC Rules.

These limits are designed to provide reasonable protection against harmful interference when the equipment is operated in a commercial environment. This equipment generates, uses and can radiate radio frequency energy and, if not installed and used in accordance with the instruction manual, may cause harmful interference to radio communications. Operation of this equipment in a residential area is likely to cause harmful interference in which case the user will be required to correct the interference at his own expense.

WARNING: The design and production of this unit conform to FCC regulations, and any changes or modifications must be registered with the FCC and are subject to FCC control. Any changes made by the purchaser or user without first contacting the manufacturer will be subject to penalty under FCC regulations.

2.5 INTERFERENCE-CAUSING EQUIPMENT STANDARD (ICES-003 IS-SUE 3) (For Canada Users)

This Class A digital apparatus complies with Canadian ICES-003.

Cet appareil numérique de la classe A est conforme à la norme NMB-003 du Canada.

2.6 For Users in countries not subject to Class B regulations

WARNING

This is a Class A product. In a domestic environment this product may cause radio interference in which case the user may be required to take adequate measures.

2.7 LED Radiation Safety

This product is a copier which operates by means of a LED (light emitting diodes) exposure system. There is no possibility of danger from the LED optical radiation, because the LED optical radiation level does not exceed the accessible radiation limit of class 1 under all conditions of operation, maintenance, service and failure.

2.8 Ozone Release

Locate the machine in a Well Ventilated Room

A negligible amount of ozone is generated during normal operation of this machine. An unpleasant odor may, however, be created in poorly ventilated rooms during extensive machine operations. For a comfortable, healthy and safe operating environment, it is recommended that the room be well ventilated.

Placer l'appareil dans une pièce largement ventilée

Une quantité d'ozone négligeable est dégagée pendant le fonctionnement de l'appareil quand celui-ci est utilisé normalement. Cependant, une odeur désagréable peut être ressentie dans les pièces dont l'aération est insuffisante et lorsque une utilisation prolongée de l'appareil est effectuée. Pour avoir la certitude de travailler dans un environnement réunissant des conditions de confort, santé et de sécurité, il est préférable de bien aérer la pièce où se trouve l'appareil.

Precautions

3

3.1 Installation Precautions

Installation Site

To ensure utmost safety and prevent possible malfunctions, install the copier in a location that meets the following requirements.

- A location away from curtains, etc. that may catch fire and burn easily
- A location that is not exposed to water or other liquids
- A location free from direct sunlight
- A location out of the direct airflow of an air conditioner or heater, and not exposed to extremely high or low temperatures
- A well-ventilated location
- A location that is not exposed to high humidity
- A location that is not extremely dusty
- A location not subjected to undue vibrations
- A stable and level location
- A location where ammonia or other organic gases are not generated
- A location that does not put the operator in the direct airflow of exhaust from the copier
- A location that is not near any kind of heating devices

Power Source

The power source requirements are as follows.

- Voltage fluctuation: Maximum $\pm 10\%$
(AC 127 V areas only: Between -10% and $+6\%$)
- Frequency fluctuation: Maximum $\pm 0.3\%$
 - Use a power source with as little voltage or frequency fluctuations as possible.

Space Requirements

To ensure easy copier operation, supply replacement, and maintenance, adhere to the recommended space requirements detailed below.

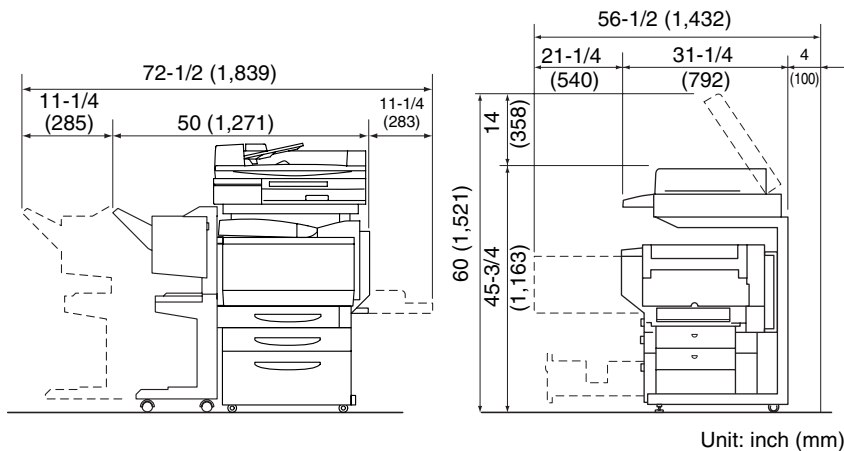

Note

Be sure to allow a clearance of 4 in. (100 mm) or more at the back of the copier for the ventilation duct.

3.2 Operation Precautions

Operating environment

The environmental requirements for correct operation of the copier are as follows.

- Temperature: 50°F (10°C) to 86°F (30°C) with fluctuations of no more than 50°F (10°C) within an hour
- Humidity: 10% to 80% with fluctuations of no more than 20% within an hour

Proper use

To ensure the optimum performance of the copier, follow the precautions listed below.

- Never place heavy objects on the original glass or subject it to shocks.
- Never open any copier doors or turn off the copier while it is making copies; otherwise, a paper jam will occur.
- Never bring any magnetized object or use flammable sprays or liquids near the copier.
- + Always make sure that the power plug is completely plugged into the electrical outlet.
- Always make sure that the copier's power plug is visible and not hidden by the copier.
- + Always unplug the copier from the electrical outlet if the unit is not to be used for a long period of time.
- + Always provide good ventilation when making a large number of continuous copies.

**CAUTION**

If the ventilation duct at the top of the copier becomes blocked, the inside of the copier will accumulate heat, resulting in a malfunction or fire.

- Do not place any objects over the ventilation duct.

**CAUTION**

The area around the fusing unit is extremely hot.

- Be careful not to touch any parts around the fusing unit, other than those indicated in this manual, in order to reduce the risk of burns. Be especially careful not to touch parts marked with warning labels, and their surrounding areas.
- If you get burnt, immediately cool the skin under cold water, and then seek professional medical advice.

Transporting the copier

If you need to transport the copier over a long distance, consult your technical representative.

Care of copier supplies

Use the following precautions when handling the copier supplies (toner cartridge, paper, etc.).

- + Store the supplies in a location that meets the following requirements.
 - Free from direct sunlight
 - Away from any heating apparatus
 - Not subjected to high humidity
 - Not extremely dusty
- + Store in a sealed plastic bag in a cool, dark place paper that has been removed from its wrapper but not loaded into the copier.
- Only use toner that has been manufactured specifically for this copier. Never use other types of toner.
- Keep all supplies out of the reach of children.



CAUTION**Precautions for handling toner:**

- Be careful not to spill toner inside the copier or get toner on your clothes or hands.
 - If your hands become soiled with toner, immediately wash them with soap and water.
 - If toner gets in your eyes, immediately flush them with water, and then seek professional medical advice.
-

Storage of copies

- + Copies that are to be kept for a long time should be kept where they are not exposed to light in order to prevent them from fading.
- Adhesive that contains solvent (e.g., spray glue) may dissolve the toner on copies.
- Color copies have a thicker layer of toner than normal black-and-white copies. Therefore, when a color copy is folded, the toner at the fold may peel off.

3.3 Legal Restrictions on Copying

Certain types of documents must never be copied with the purpose or intent to pass copies of such documents off as the originals.

The following is not a complete list, but is meant to be used as a guide to responsible copying.

<Financial Instruments>

- Personal checks
- Travelers checks
- Money orders
- Certificates of deposit
- Bonds or other certificates of indebtedness
- Stock certificates

<Legal Documents>

- Food stamps
- Postage stamps (canceled or uncanceled)
- Checks or drafts drawn by government agencies
- Internal revenue stamps (canceled or uncanceled)
- Passports
- Immigration papers
- Motor vehicle licenses and titles
- House and property titles and deeds

<General>

- Identification cards, badges, or insignias
- Copyrighted works without permission of the copyright owner

In addition, it is prohibited under any circumstances to copy domestic or foreign currencies, or works of art without permission of the copyright owner.

When in doubt about the nature of a document, consult with legal counsel.

***Part Names
and Their
Functions***

4

4.1 Components and Their Functions

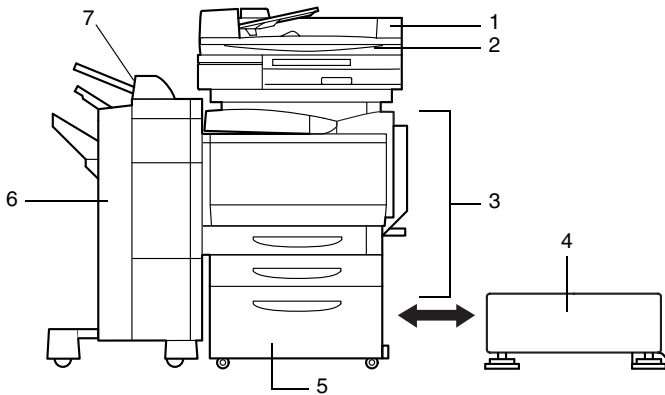

No.	Part Name	Description
1	Duplexing Document Feeder AFR-18 (optional)	Automatically feeds and scans one document sheet at a time, and automatically turns over double-sided documents and scans them Referred to as the duplexing document feeder throughout the manual
2	Scanner SC-1	Scans the document Referred to as the scanner throughout the manual; in addition, the combination of the scanner and the printer is referred to as the copier .
3	Copier printer section	Prints the image scanned with the scanner Referred to as the printer throughout the manual; in addition, the combination of the scanner and the printer is referred to as the copier .
4	Copy Desk CD-2M (optional)	The printer can be set up on the copy desk. By setting up the printer on the copy desk, the printer can be placed on the floor instead of on a desk, keeping the entire surface of the desk free. Referred to as the copy desk throughout the manual
5	Large Capacity Cabinet PF-121 (optional)	Equipped with a paper drawer that can supply 2,500 sheets of paper Referred to as the large capacity cabinet throughout the manual
6	Finisher FN-116 (optional)	Finishes copies according to the selected Finishing setting (sorting or stapling), then feeds out the pages <ul style="list-style-type: none"> If the finisher is installed, the printer must be installed on the copy desk, on the large capacity cabinet or over a paper feed unit combined with the copy table.
7	Option Tray JS-100 (optional)	If finisher FN-116 is installed, the number of paper output trays can be increased.

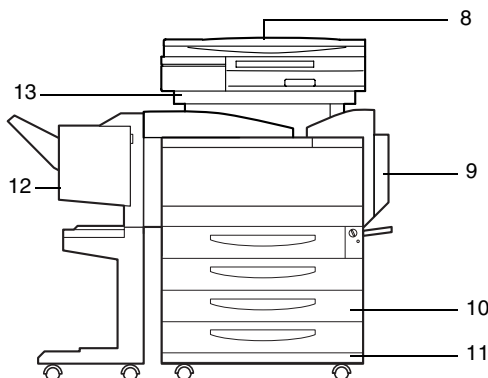

No.	Part Name	Description
8	Original Cover OC-2 (optional)	Presses down on the loaded document to keep it in place Referred to as the original cover throughout the manual
9	Duplex Unit AD-14 (optional)	Turns over copies, allowing double-sided copies to be made automatically. <ul style="list-style-type: none"> If a printer controller (CN3102Pro or CN3102e) and the duplex unit are installed on the CF3102, the memory must be expanded. If the optional memory is not installed, automatic double-sided copying cannot be performed. Referred to as the duplex unit throughout the manual
10	Paper Feed Unit PF-118 (optional)	Equipped with a paper drawer that can supply 500 sheets of paper; up to two paper feed units can be installed. Referred to as the paper feed unit throughout the manual
11	Copy Table CT-2 (optional)	A paper feed unit can be set up on the copy table, and then the printer can be set up on the top. By setting up the printer on the copy table, the printer can be placed on the floor instead of on a desk, keeping the entire surface of the desk free. Referred to as the copy table throughout the manual
12	Finisher FN-8 (optional)	Finishes copies according to the selected finishing mode (sorting, stapling, hole-punching or binding), then feeds out the pages <ul style="list-style-type: none"> The hole-punching function is only available if the optional punch kit (PK-4) is installed onto finisher FN-8. If the finisher is installed, the printer must be installed on the copy desk, on the large capacity cabinet or over a paper feed unit combined with the copy table.
13	Copier Stand CS-2 (optional)	Reduces the installation area required for the equipment if the scanner is installed on the top of the stand and the printer is installed on the inside Referred to as the copier stand throughout the manual

No.	Part Name	Description
14	Punch KIT PK-4 (optional)*	Allows the hole-punching function to be used if installed onto finisher FN-8
15	Memory M256-2 (US, Canada: Standard, Others: Optional)	Increases the memory of the copier to 512 MB (256 MB standard memory + 256 MB expanded memory) By expanding the memory, the number of pages that can be stored in the memory can be increased. (Refer to Supplemental Table 1.) Referred to as the memory throughout the manual
16	Hard Disk Drive HDD-5 (optional)*	Allows more pages to be stored (Refer to Supplemental Table 1.) In addition, by installing hard disk drive HDD-5 and the optional memory, the "Distribution" function can be used. Referred to as the hard disk throughout the manual
17	Printer Controller CN3101e (optional)*	Internal printer controller that allows the copier to be used as both a color printer and a color scanner configured into a computer network For more details, refer to the manual of the printer controller.
18	Printer Controller CN3102Pro (optional)*	External printer controller that allows the copier to be used as both a color printer and a color scanner configured into a computer network For more details, refer to the manual of the printer controller.
19	Printer Controller CN3102e (optional)*	Stationary printer controller that allows the copier to be used as both a color printer and a color scanner configured into a computer network For more details, refer to the manual of the printer controller.

* The internal options are not shown.

Supplemental Table 1

Number of Document Pages Stored / Document Type	Standard Configuration		With Optional Memory Installed (US, Canada: Standard, Others: Optional)		With Optional Memory and the Hard Disk Installed	
	Color	Black & white	Color	Black & white	Color	Black & white
Text only	60 sheets	197 sheets	137 sheets	400 sheets	Maximum 2,000 sheets	
Text and images	20 sheets	149 sheets	46 sheets	340 sheets		
Photographs						
Maps						

* The number of document pages that can be stored was calculated based on our standard document page. The number of pages that can be stored will vary depending on the document.

4.2 Parts Names and Their Functions

Outside of Copier

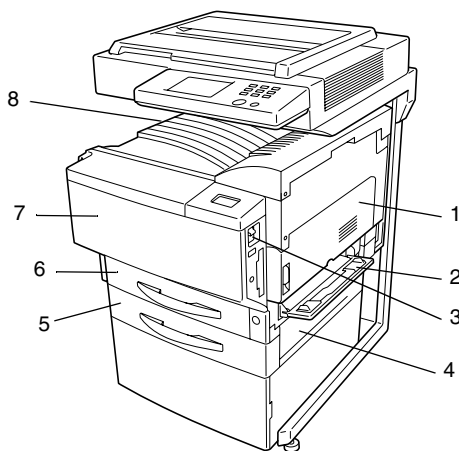

*The illustration above shows the optional original cover, copier stand and copy desk installed.

No.	Part Name	Description
1	Right-side door	Opened when clearing misfeeds
2	Manual bypass tray	Used for manual feeding of paper The paper is fed one sheet at a time. Special paper can be loaded. (See section 3.5 in the Basic Operations volume.)
3	Power switch	Used to turn the copier on and off (See section 1.5 in the Basic Operations volume.)
4	Lower right-side door	Opened when clearing misfeeds
5	2nd drawer	Holds up to 500 sheets of paper The paper size can be adjusted freely. (See section 3.5 in the Basic Operations volume.)
6	1st drawer	Holds 250 sheets of paper The paper size can be adjusted freely. Special paper can be loaded. (See section 3.5 in the Basic Operations volume.)
7	Front door	Opened when replacing a toner cartridge (See p. 6-5)
8	Copy output tray	Collects copies fed out of the copier facing down

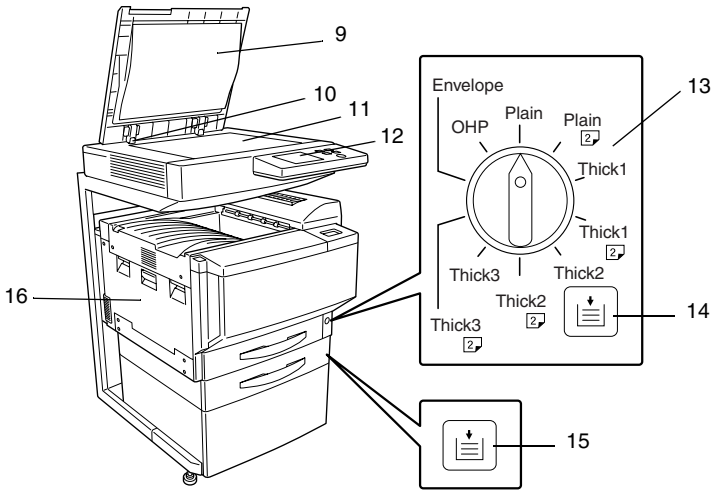

*The illustration above shows the optional original cover, copier stand and copy desk installed.

No.	Part Name	Description
9	Original Cover (optional)	Presses the document against the original glass
10	Document scale	Used to align the document (See section 4.2 in the Basic Operations volume.)
11	Original glass	When manually feeding the document, place it on the glass so the document can be scanned. Place the document face down on the glass. (See section 4.2 in the Basic Operations volume.)
12	Control panel	Used to start copying or to make settings (See section 1.3 in the Basic Operations volume.)
13	Media type selection dial	Used to specify the type of paper loaded into the 1st drawer
14	1st drawer Paper-empty indicator	Indicates the amount of paper remaining <ul style="list-style-type: none"> Flashing: Indicates that there is little paper remaining Lit: Indicates that the paper is empty Replenish the paper.
15	2nd drawer Paper-empty indicator	
16	Left-side door	Opened when servicing the copier

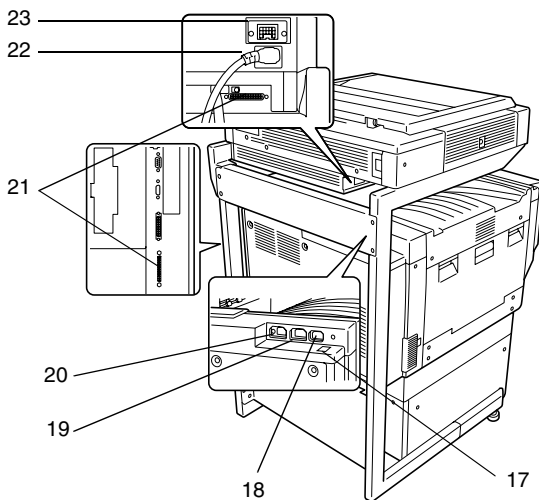

*The illustration above shows the optional original cover, copier stand and copy desk installed.

No.	Part Name	Description
17	Finisher connector	Used for connecting the finisher hookup cord
18	Printer power cord socket	Used for connecting the printer's power cord
19	Scanner power cord outlet	Used for connecting the scanner's power cord
20	Power cord socket for Printer Controller CN3102e	Used for connecting the power cord for printer controller CN3102e
21	Scanner connector	Used for connecting the scanner hookup cord
22	Scanner power cord socket	Used for connecting the scanner's power cord
23	Duplexing Document Feeder connector	Used for connecting the duplexing document feeder hookup cord

Supplies and Parts

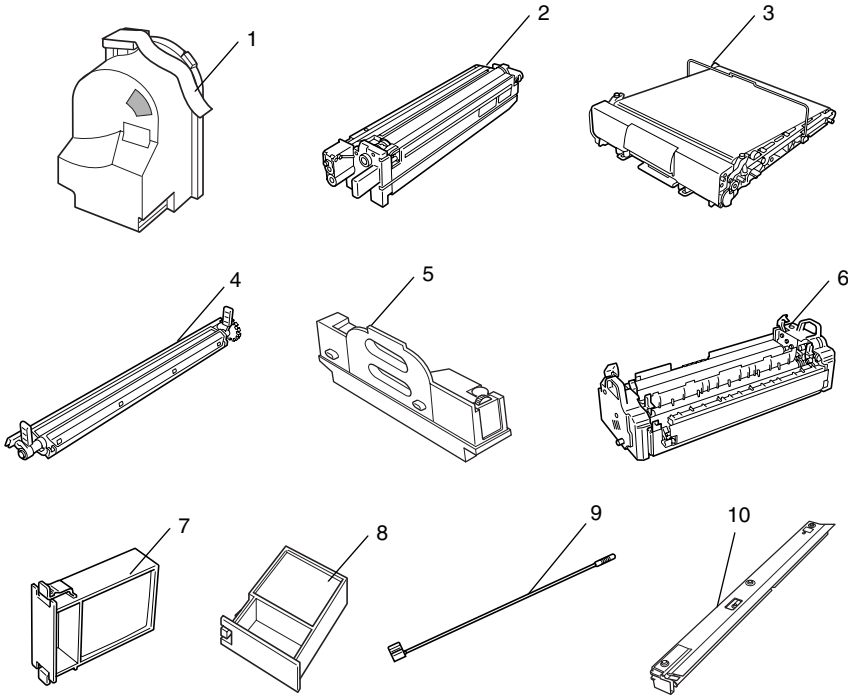

No.	Part Name	Description
1	Toner Cartridge	There are four toner cartridges: cyan (C), magenta (M), yellow (Y) and black (BK). The combination of the four toners generates full-color images.
2	Imaging Unit	Generates the copied image
3	Image transfer belt unit	Lays onto the image transfer belt each of the single colors of the image generated by the imaging unit in order to create a full-color image
4	Image transfer roller unit	Transfers onto the paper a full-color image generated by the image transfer belt unit
5	Waste-toner bottle	Collects waste toner
6	Fusing unit	Fuses the transferred toner to the paper
7	Ozone filter	Collects the ozone generated in the copier
8	Filter	Collects the toner dust generated in the copier
9	LED-cleaning tool	Used to clean the surface of the LED unit, for example, when replacing the image transfer belt unit
10	Dust remover	Collects the dust generated in the copier

Inside of Copier

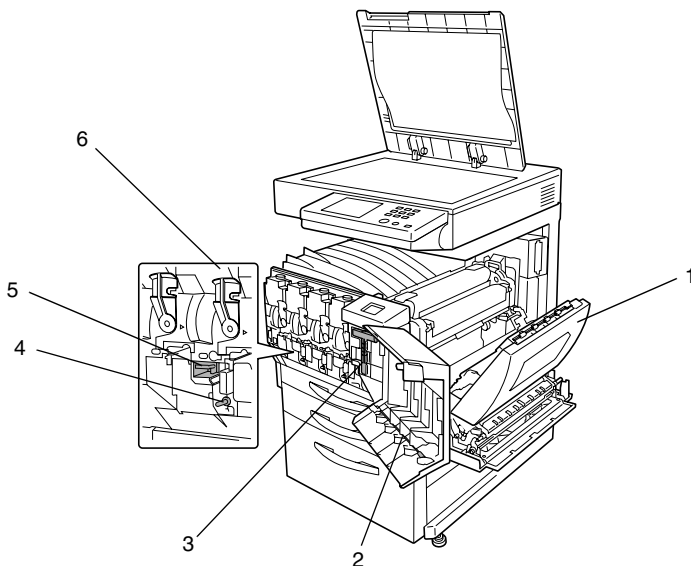

No.	Part Name	Description
1	Upper right-side door	Opened when replacing the fusing unit or clearing misfeeds
2	LED-cleaning tool	Used to clean the surface of the LED unit, for example, when replacing the image transfer belt unit
3	Imaging unit removal bracket	Used to remove the imaging unit
4	Charger-cleaning tool	Used to clean the electrostatic charger wire, for example, when incorrect copies are produced
5	Imaging unit release lever	Used to install and replace the imaging unit
6	Toner cartridge compartments	Contains a toner cartridge for each color

Options

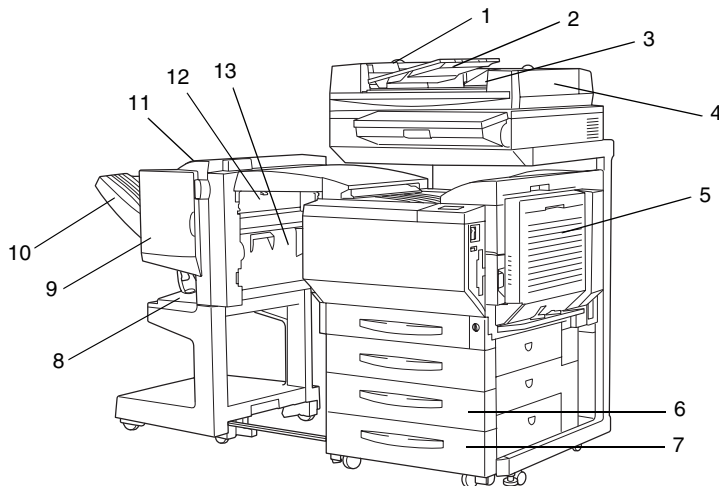

Duplexing Document Feeder

No.	Part Name	Description
1	Adjustable document guide	Adjust to the width of the document. (See section 4.2 in the Basic Operations volume.)
2	Document feed tray	Load the documents to be copied face up. (See section 4.2 in the Basic Operations volume.)
3	Document output tray	Collects documents that have been copied
4	Misfeed-clearing cover	Opened when clearing a misfed document

Duplex Unit

No.	Part Name	Description
5	Duplex unit door	Opened when clearing a paper misfeed within the duplex unit

Paper Feed Unit

No.	Part Name	Description
6	3rd drawer	Holds up to 500 sheets of paper As many as two units can be installed. The paper size can be adjusted freely.
7	4th drawer	

Finisher (FN-8)

No.	Part Name	Description
8	Lower paper output tray (bound paper tray)	Collects copies that were bound
9	Front door	Opened when replacing the staple cartridge
10	Paper output tray (elevated tray)	Collect copies
11	Upper door	Opened when clearing a paper misfeed within the finisher
12	Paper guide	Opened when clearing a paper misfeed within the finisher
13	Transport guide	Opened when clearing a paper misfeed within the finisher

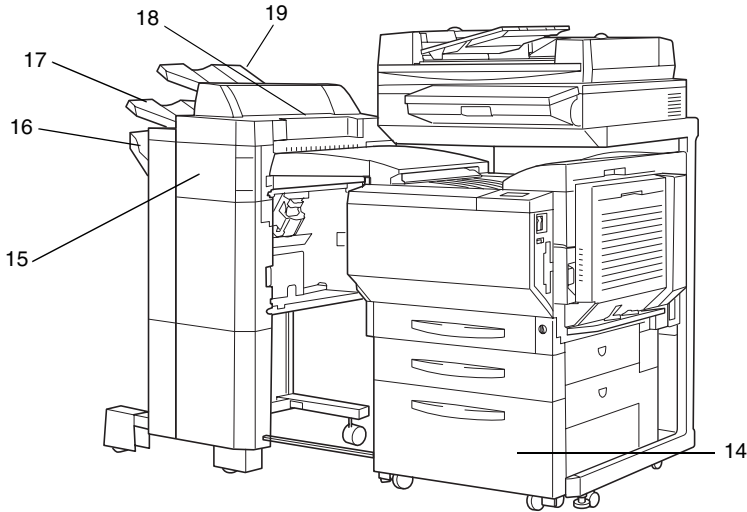

Large Capacity Cabinet

No.	Part Name	Description
14	3rd drawer	Holds up to 2,500 sheets of paper (See section 3.5 in the Basic Operations volume.)

Finisher (FN-116)

No.	Part Name	Description
15	Front door	Opened when clearing a paper misfeed within the finisher
16	Secondary paper output tray (sorted copies)	Collects copies that are sorted
17	Primary paper output tray (non-sorted copies)	Collects copies that are not sorted (made with the "Non-Sort" setting)
18	Upper cover	Opened when clearing a paper misfeed within the finisher

Option Tray

No.	Part Name	Description
19	Option Tray (optional)	Collects copies

*Utility Mode
Operations*

5

5.1 Utility Screen

The functions available on the Utility screen, displayed by pressing the [Utility] key, are described below.

If the [Utility] key is pressed, the following screen appears.

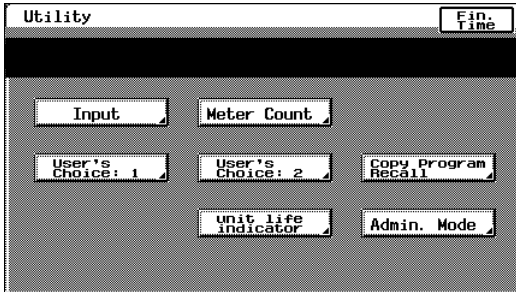

Input (Refer to p. 5-3)

- “Reset Mode” function: The initial mode settings, selected after the copier is reset, can be changed.
- “Job Memory Input” function: Up to 10 copy modes can be stored as copy programs.

User's Choice: 1 **User's Choice: 2** (Refer to p. 5-7)

- The various functions can be set according to the user's needs.
- There are two User's Choice screens.
 - The functions that can be set while a job is printing are on the User's Choice: 1 screen, and the functions that can be set while the copier is waiting to print are on the User's Choice: 2 screen.

Meter Count (Refer to p. 5-32)

- The various counters, showing the number of copies that have been made since the copier was installed, can be viewed.

unit life indicator (Refer to p. 5-34)

- The level of use for the various supplies and parts can be checked.

Copy Program Recall (Refer to p. 5-6)

- The various copy programs stored with the “Job Memory Input” function, described above, can be recalled.

Admin. Mode (Refer to p. 5-35)

- The Administrator mode allows the use of the copier to be controlled, by allowing various functions to be set according to the use.
- The administrator access code (4-digit password) must be entered in order to set the Administrator mode functions. For details on the administrator access code, contact the technical representative.

Specifying the Input Screen Functions

The following two functions are available on the Input screen (when [Input] is touched).

 (Refer to page 5-4)

- The initial mode settings, selected after the copier is reset, can be changed.

 (Refer to p. 5-5)

- User-specified copy modes can be stored as copy programs.
- Up to 10 specified copy modes can be stored as copy programs. These stored copy programs can be recalled by touching [Copy Program Recall] on the Utility screen.

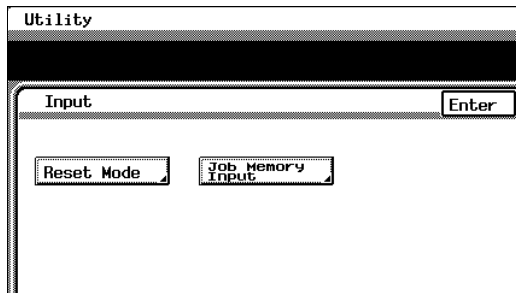

Specifying the Initial Mode Settings (“Reset Mode” Function)

The mode selected when the power switch is turned on (set to “I”) is called the initial mode.

The settings for the mode selected when the power switch is turned on (set to “I”) can be specified using the “Reset Mode” function.

To specify the initial mode settings

- 1 Select the desired Copy mode settings.
 - For details on selecting Copy mode settings, refer to “Specifying Copy Settings” in the Basic Operations volume.
- 2 Press the [Utility] key.
- 3 Touch [Input].
- 4 Touch [Reset Mode].

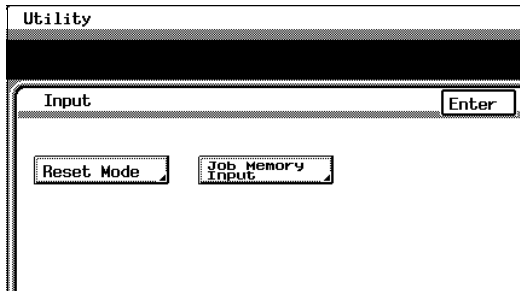

- 5 Touch [Set-up Mode].
- 6 Touch [Input].



Note

If [Set-up Mode] is selected, the current Copy mode settings are stored as the initial mode settings.

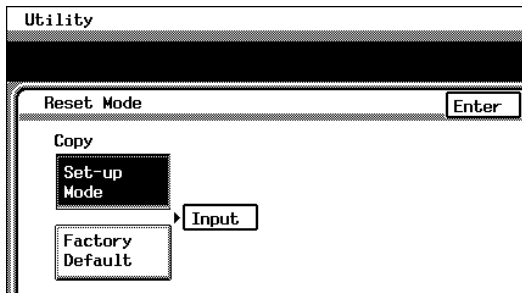

- 7 Touch [Enter], and then touch [Enter] again in the screen that appears.
- 8 Touch [Fin. Time].

Using Copy Programs

A user-specified copy mode can be stored as a copy program.

Each of the 10 copy programs that can be stored can be given a name (up to 9 characters long).

To store a copy program

- 1 Select the desired Copy mode settings.
 - For details on selecting Copy mode settings, refer to “Specifying Copy Setting” in the Basic Operations volume.
- 2 Press the [Utility] key.
- 3 Touch [Input].
- 4 Touch [Job Memory Input].
- 5 Touch the number of the program where you wish to store the settings.

A screen appears, allowing you to enter the name of the program.

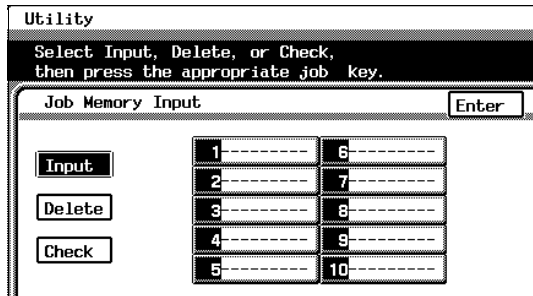

- 6 Touch the letters and numbers to enter a name (9 characters long) for the copy job, and then touch [Enter].

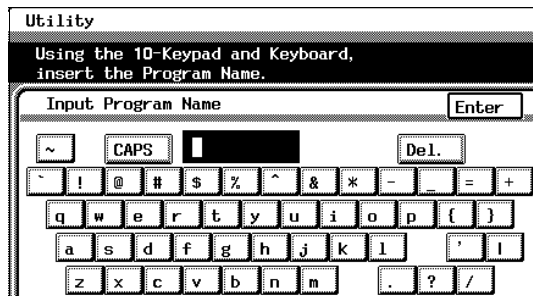

- **To delete a copy program**
Touch [Delete], and then touch the number of the program that you wish to delete. When the number of the program is selected, the program is deleted.
- **To check the specified settings of a program**
Touch [Check], and then touch the number of the program that you wish to check. The specified Copy mode settings are displayed. To return to the Job Memory Input screen, touch [Enter].

- 7 Touch [Enter], and then touch [Enter] again in the screen that appears.
- 8 Touch [Fin. Time].
The Basic screen appears again.

To recall a stored copy program and use it to make copies

The stored copy programs can be recalled to be used again, as necessary.

Recall the copy programs by touching [Copy Program Recall] on the Utility screen.

- 1 Press the [Utility] key.
- 2 Touch [Copy Program Recall].
- 3 Touch the number of the program that you wish to recall.

The copy program settings appear.

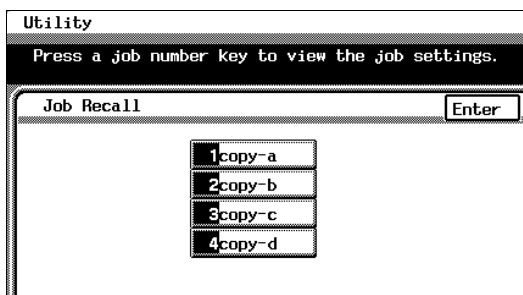

- 4 Check that the copy program settings that appear are the ones that you wish to use, and then touch [Enter]. The Copy mode settings change to the ones that are recalled.

If the displayed copy program settings are not the ones that you wish to use, touch [Menu].

The Job Recall screen appears again. Touch the correct number of the program that you wish to recall.

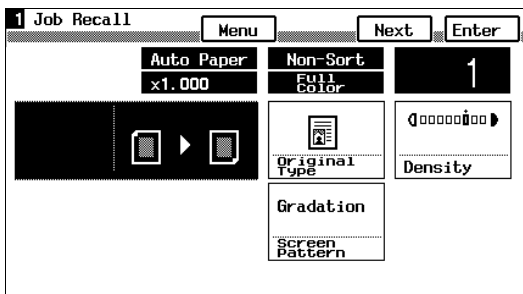

- 5 Press the [Start] key. The copy job is queued for printing with the recalled Copy mode settings.

5.2 Specifying Default Settings (“User’s Choice” Functions)

With the User’s Choice function, the initial mode settings can be customized according to how the copier is to be used.

User’s Choice: 1 Screens

User's Choice: 1		Exit
1/2	2/2	
Confirmation Beep	ON	
Date/Time Set	2003/01/27 / +0000	
Memory Recall	Yes	
Key Repeat Start/Interval	0.8 Sec / 0.5 Sec	

User's Choice: 1		Exit
1/2	2/2	
Auto Panel Reset	1 min.	
Energy Saver	15 min.	
Sleep	30 min.	
Auto Clear Mode	Yes	
Enlarge-Display Notice	No	

Confirmation Beep (Refer to p. 5-10)

- This function is used to specify whether or not a confirmation beep is sounded each time a key in the operation panel is pressed.

Date/Time Set (Refer to p. 5-11)

- This function is used to set the current date and time.

Memory Recall (Refer to p. 5-13)

- This function is used to set the memory recall feature, which allows settings from past copy jobs to be recalled.

Key Repeat Start/Interval (Refer to p. 5-15)

- This function is used to specify the length of time until the repeat feature for a key starts and the length of the time that a key must be held down between subsequent repeats.

Auto Panel Reset (Refer to p. 5-16)

- This function is used to specify the length of time after the last operation until all functions return to their default settings.

Energy Saver (Refer to p. 5-17)

- This function is used to specify the length of time after the last operation until the copier automatically enters Energy Saver mode.

Sleep (Refer to p. 5-18)

- This function is used to specify the length of time after the last operation until the copier automatically enters Sleep mode.

Auto Clear Mode

(Refer to p. 5-19)

- This function is used to specify whether all modes and functions are automatically reset when the magnetic card is removed from the data controller or the key counter is removed.

**Enlarge-Display
Notice**

(Refer to p. 5-20)

- This function is used to specify the length of time that the message requesting confirmation to cancel the Enlarge Display mode is displayed.

User’s Choice: 2 Screens

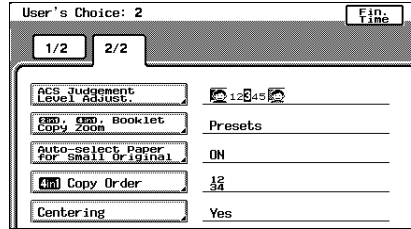
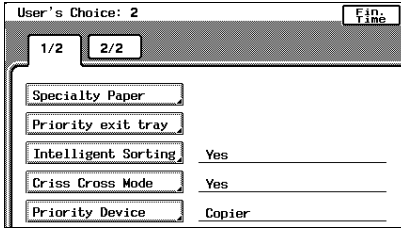

Specialty Paper (Refer to p. 5-21)

- This function is used to specify the special paper settings for each paper drawer.

Priority exit tray (Refer to p. 5-23)

- This function is used to set the priority order of the paper output trays.

Intelligent Sorting (Refer to p. 5-24)

- This function is used to specify whether the “Sort” setting is automatically selected if the document consists of 2 or more pages.

Criss Cross Mode (Refer to p. 5-25)

- This function is used to set whether or not copies will be sorted in a crisscross pattern if the necessary conditions are met while using the “Sort” or “Group” settings.

Priority Device (Refer to p. 5-26)

- This function is used to specify the print timing for print jobs that have been received.

ACS Judgement Level Adjust. (Refer to p. 5-27)

- This function is used to adjust the level for detecting whether a document will be copied in color or in black and white.

2in1, 4in1, Booklet Copy Zoom (Refer to p. 5-28)

- This function is used to specify the zoom ratios for 2in1 and 4in1 copying, and booklet binding.

Auto-select Paper for Small Original (Refer to p. 5-29)

- This function is used to specify how small-sized documents are printed using the “Auto Paper” setting.

4in1 Copy Order (Refer to p. 5-30)

- This function is used to specify the page order for 4in1 copying.

Centering (Refer to p. 5-31)

- This function is used to specify whether or not the image is centered when the document is smaller than the paper.

To set the “Confirmation Beep” function

This function is used to specify whether or not a confirmation beep is sounded each time a key in the operation panel is pressed. (The default setting is [ON].)

- 1 Press the [Utility] key.
- 2 Touch [User’s Choice: 1].
- 3 Touch [Confirmation Beep].

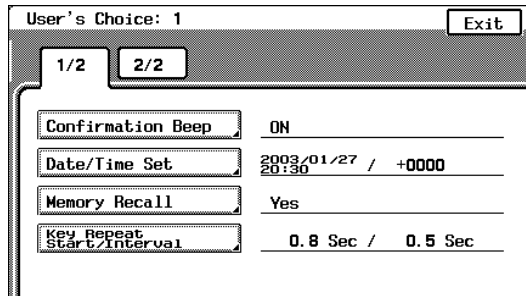

- 4 Select the desired setting.
- 5 Touch [Enter].
- 6 Touch [Fin. Time], and then touch [Fin. Time] again in the screen that appears.

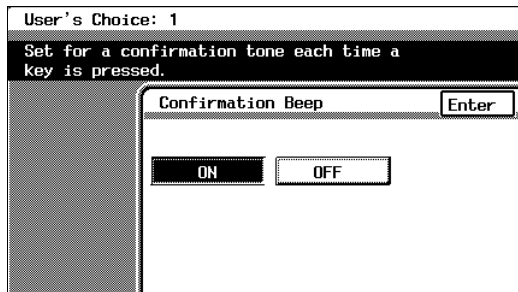

To set the “Date/Time Set” function

This function is used to set the current date and time. In addition, the time zone can be set between -1200 and +1200 (in 30 minute intervals). (The default setting is [+0000].)

- 1 Press the [Utility] key.
- 2 Touch [User’s Choice: 1].
- 3 Touch [Date/Time Set].

User's Choice: 1		Exit
1/2	2/2	
Confirmation Beep	ON	
Date/Time Set	2003/01/27 / 20:30 / +0000	
Memory Recall	Yes	
Key Repeat Start/Interval	0.8 Sec / 0.5 Sec	

- 4 Touch [Year].
- 5 Press the [C] (clear) key.
The current setting is erased.
- 6 Using the keypad, enter the year for the current date.
- 7 Specify the settings for [Month], [Day], [Hour], [min.] and [Time Zone] in the same way.
Touch [Time Zone] first before touching [+/-] to specify the time zone.



Tip

The time zone setting is the time difference from Greenwich Mean Time.

8 Touch [Enter].

The clock begins ticking.

9 Touch [Fin. Time], and then touch [Fin. Time] again in the screen that appears.

The screenshot shows a keypad interface for setting the date and time. At the top, it says "User's Choice: 1" and "Input current date and time using the Keypad. Press Enter after each entry." Below this is a "Date/Time Set" section with "Cancel" and "Enter" buttons. The date is set to 2003 (Year), 01 (Month), and 25 (Day). The time is set to 17:54. The time input is split into "Hour" (17) and "min." (54). There is a "+/-" button and a "+ 0000" button for the "Time Zone" field.

Date/Time Set		Cancel	Enter
Time		17:54	
2003	01	25	
Year	Month	Day	
17	54	+/-	+ 0000
Hour	min.	Time Zone	

To set the “Memory Recall” function

Memory recall function (The default setting is [Yes].)

- ✓ This feature allows past copy jobs to be recalled and printed again.
- ✓ Up to 49 past copy jobs are saved.
- ✓ If the number of copy jobs exceeds 49 or the memory becomes full, jobs are deleted, starting from the oldest.
- ✓ Deleted jobs cannot be recalled. For details on recalling past copy jobs, refer to “Original Documents/Feeding the Document” in the Basic Operations volume.
- ✓ The “Memory Recall” function and the “Copy Track” function cannot be used at the same time. In order to use the “Memory Recall” function, the “Copy Track Mode” parameter on the “Copy Track” screen must be set to “No”. For details on setting the “Copy Track Mode” parameter on the “Copy Track” screen, refer to “To set the “Copy Track Mode” parameter” in chapter 5 “Utility Mode Operations” of the Administrator Operations volume.

- 1 Press the [Utility] key.
- 2 Touch [User’s Choice: 1].
- 3 Touch [Memory Recall].

User's Choice: 1		Exit
1/2	2/2	
Confirmation Beep	ON	
Date/Time Set	2003/01/27 / +0000	
Memory Recall	Yes	
Key Repeat Start Interval	0.8 Sec / 0.5 Sec	

**Note**

If the “Copy Track Mode” parameter on the “Copy Track” screen is set to “Yes”, the Memory Recall job control screen cannot be displayed, even if [Memory Recall] is touched. If the “Memory Recall” function on the User’s Choice: 1 screen is set to “Yes”, setting the “Copy Track Mode” parameter on the “Copy Track” screen to “Yes” automatically changes the “Memory Recall” function to “No”.

For details on setting the “Copy Track Mode” parameter on the “Copy Track” screen, refer to “To set the “Copy Track Mode” parameter” of “Supervising Copier Use (Copy Track Functions)” in chapter 5 “Utility Mode Operations”.

- 4 Select the desired setting.
- 5 Touch [Enter].
- 6 Touch [Fin. Time], and then touch [Fin. Time] again in the screen that appears.

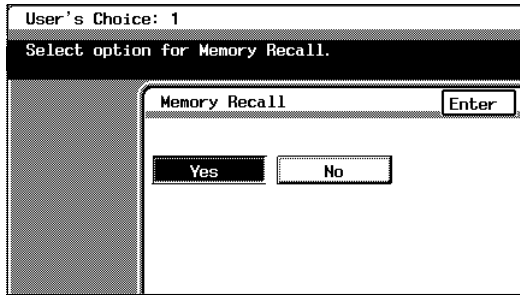

To set the “Key Repeat Start Time/Interval” function

The length of time until the repeat feature for a key starts when a key in the touch panel is held down can be specified. (The default setting for the start time is 0.8 second and the default setting for the repeat interval is 0.1 second.)

For more details, refer to “Repeat Feature for Keys” in “Before Making Copies” of the Enlarge Display Operations volume.



Note

The settings for the repeat feature are only applied in the Enlarge Display mode; they are not applied when the screen is displayed normally.

- 1 Press the [Utility] key.
- 2 Touch [User’s Choice: 1].
- 3 Touch [Key Repeat Start Time/Interval].

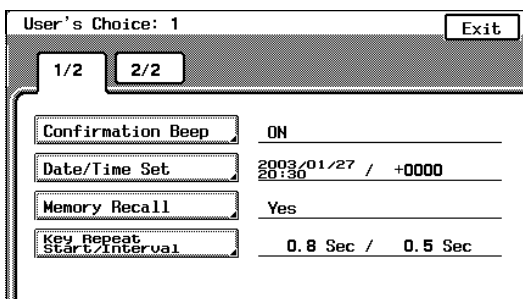

- 4 Touch [▲] and [▼] to specify the desired length of time until the repeat feature for a key starts (between 0.1 and 3.0 seconds).

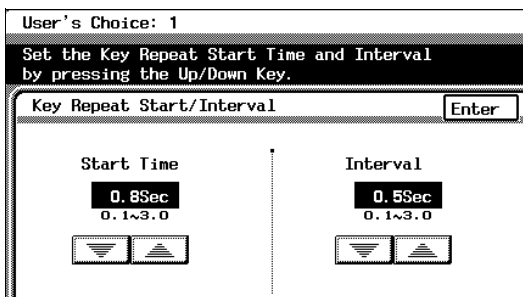

- 5 Touch [Enter].
- 6 Touch [Fin. Time], and then touch [Fin. Time] again in the screen that appears.

To set the “Auto Panel Reset” function

This function is used to specify the length of time after the last operation until all functions automatically return to their default settings. (The default setting is [1 min.])

For details on the automatic panel reset, refer to “Original Documents/Feeding the Document” in the Basic Operations volume.

- 1 Press the [Utility] key.
- 2 Touch [User’s Choice: 1].
- 3 Touch [2/2].

- 4 Touch [Auto Panel Reset].

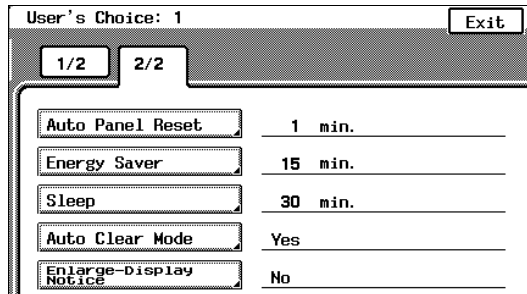

- 5 Press the [C] (clear) key. The current setting is erased.

- 6 Using the keypad, enter the desired length of time (between 1 and 9 minutes).

- If you do not wish for the copier to automatically reset its modes and functions, touch [No].

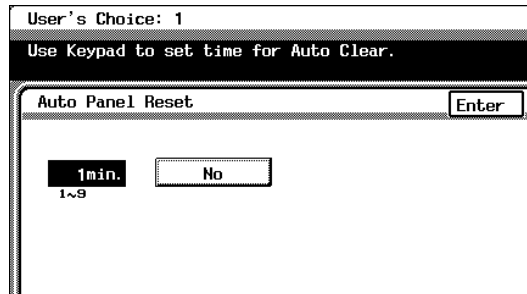

- 7 Touch [Enter].

- 8 Touch [Fin. Time], and then touch [Fin. Time] again in the screen that appears.

To set the “Energy Saver” function

This function is used to specify the length of time after the last operation until the copier automatically enters Energy Saver mode. (The default setting is [15 min.]) for entering Energy Saver mode.

For details on the Energy Saver mode, refer to “Original Documents/Feeding the Document” in the Basic Operations volume.

- 1 Press the [Utility] key.
- 2 Touch [User’s Choice: 1].
- 3 Touch [2/2].
- 4 Touch [Energy Saver].

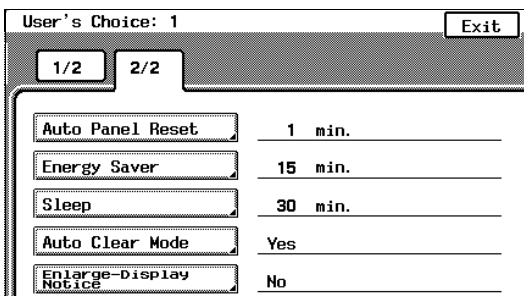

- 5 Press the [C] (clear) key.
The current setting is erased.

- 6 Using the keypad, enter the desired length of time (between 10 and 240 minutes).

- 7 Touch [Enter].

- 8 Touch [Fin. Time], and then touch [Fin. Time] again in the screen that appears.

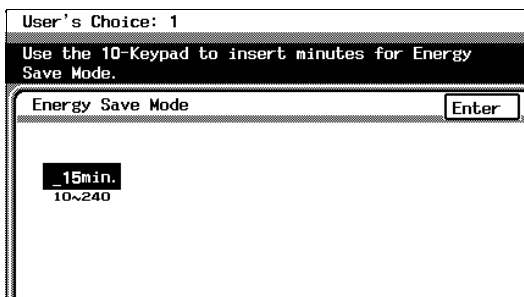

To set the “Sleep” function

This function is used to specify the length of time after the last operation until the copier automatically enters Sleep mode. The copier only enters Sleep mode if the “Disable Sleep Mode” function of the Administrator mode is set to “No”. (The default setting is “30 min.”.)

For details on the Sleep mode, refer to “Original Documents/Feeding the Document” in the Basic Operations volume.

- 1 Press the [Utility] key.
- 2 Touch [User’s Choice: 1].
- 3 Touch [2/2].
- 4 Touch [Sleep].

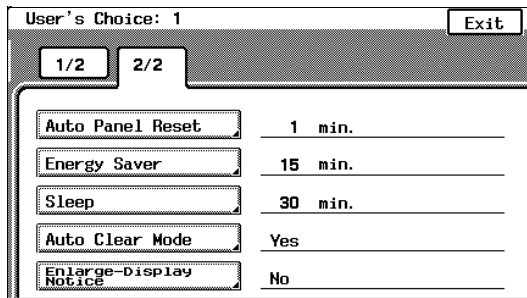

- 5 Press the [C] (clear) key.
The current setting is erased.

- 6 Using the keypad, enter the desired length of time (between 15 and 240 minutes).

- If you do not want the copier to enter Sleep mode, touch [No].

- 7 Touch [Enter].

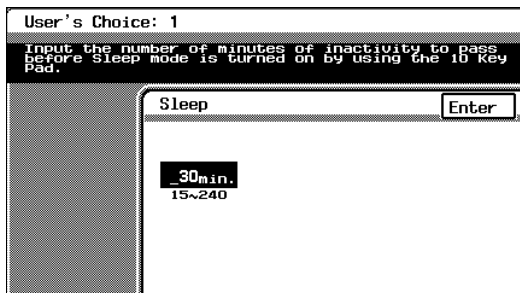

- 8 Touch [Fin. Time], and then touch [Fin. Time] again in the screen that appears.

To set the “Auto Clear Mode” function

This function is used to specify whether or not the copier clears all settings when it detects that the user of the copier has changed, for example, when the magnetic card has been removed from the optional data controller or when the key counter has been removed. (The default setting is [Yes].)

For details on clearing all settings when a new user is detected, refer to “Original Documents/Feeding the Document” in the Basic Operations volume.

- 1 Press the [Utility] key.
- 2 Touch [User’s Choice: 1].
- 3 Touch [2/2].
- 4 Touch [Auto Clear Mode].

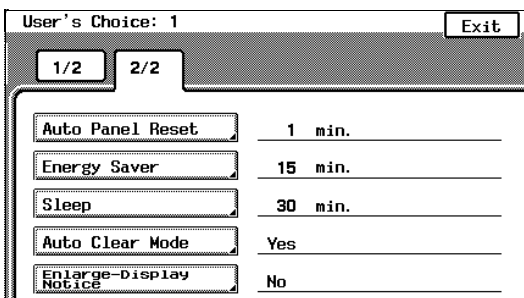

- 5 Select the desired setting.
- 6 Touch [Enter].
- 7 Touch [Fin. Time], and then touch [Fin. Time] again in the screen that appears.

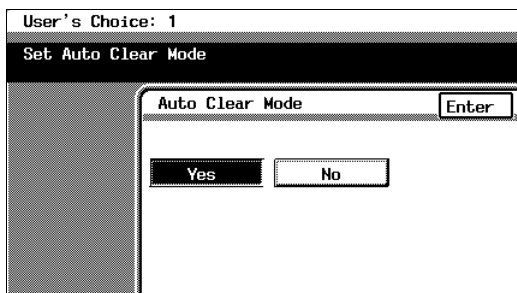

To set the “Enlarge-Display Notice” function

If the “Auto Clear Mode” function is set to “Yes”, the message requesting confirmation to cancel the Enlarge Display mode can be displayed. (The default setting is “No”.)

In addition, it is possible to specify the length of time that the message requesting confirmation to cancel the Enlarge Display mode is displayed.

For more details, refer to “Confirming the Cancellation of the Enlarge Display Mode” in “Before Making Copies” of the Enlarge Display Operations Guide.

- 1 Press the [Utility] key.
- 2 Touch [User’s Choice: 1].
- 3 Touch [2/2].
- 4 Touch [Enlarge-Display Notice].

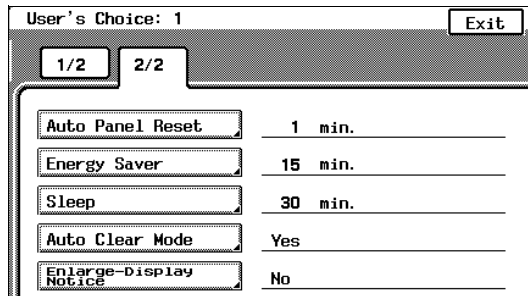

- 5 Select the desired setting and specify the length of time (30, 60, 90 or 120 seconds) that the message requesting confirmation to cancel the Enlarge Display mode is displayed.

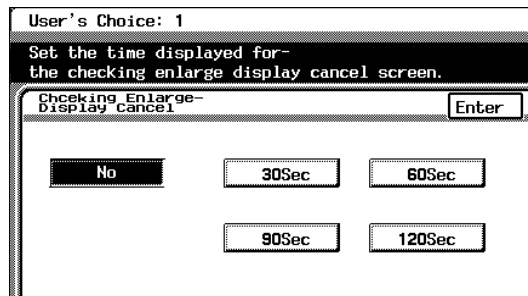

- 6 If you do not wish for the message requesting confirmation to cancel the Enlarge Display mode to appear, touch [No].
- 7 Touch [Enter].
- 8 Touch [Fin. Time], and then touch [Fin. Time] again in the screen that appears.

“Specialty Paper” Settings

This function is used to specify that the paper loaded into any paper drawer is special paper. (The default setting is [Standard].)

If the drawer is set to “Specialty”, the paper is not automatically selected with Paper setting “Auto Paper” or with double-sided copying.

To print on special paper, select the paper drawer loaded with special paper.

When printing regardless of the paper type, paper in a drawer set to “Standard” is selected with Paper setting “Auto Paper”.

When printing regardless of the paper type, paper set to “Standard” is selected with the automatic selection functions.

Only with special printing is the “Specialty” paper setting selected for making copies.

“Standard” setting



- Select this setting if plain paper is loaded. This is the default setting.
- Paper with this setting can be automatically selected with the paper setting “Auto Paper” and Zoom setting “Auto Size”.

“High Quality Paper” setting



- Select this setting when using High Quality paper.
- Paper with this setting is not automatically selected with the Paper setting “Auto Paper”.

“Single Sided Only” setting



- Select this setting for paper that should not be used with double-sided copying (for example, when one side has already been printed on).
- Paper with this setting is not automatically selected during automatic double-sided copying.

“Specialty” setting



- Select this setting for paper, other than “High Quality Paper” or “Single Sided Only” paper, that should not be selected automatically.
- Paper with this setting is not automatically selected with the Paper setting “Auto Paper”.

To set the “Specialty Paper” function

- 1 Press the [Utility] key.
- 2 Touch [User’s Choice: 2].
- 3 Touch [Specialty Paper].

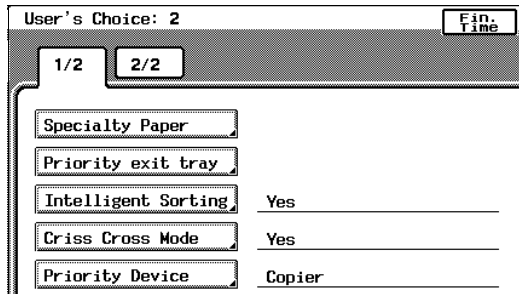

- 4 Select the paper drawer that you wish to set.
- 5 Select the desired paper setting.
- 6 Touch [Enter].
- 7 Touch [Fin. Time], and then touch [Fin. Time] again in the screen that appears.

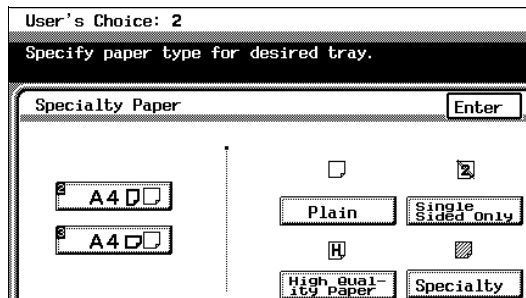

Specifying the Output Tray Priority

The “Priority exit tray” function is used to specify the output tray that is given priority for each application.

This function can be set only if the finisher (FN-116) is installed.

(The default settings are tray “2” for copying and printing, and tray “3” for Internet faxing.)

Applications

The applications referred to here are copying, PC printing and Internet fax printing (Internet faxing).

PC printing and Internet fax printing can only be used if the optional printer controller is installed.

To set the “Priority exit tray” function

- 1 Press the [Utility] key.
- 2 Touch [User’s Choice: 2].
- 3 Touch [Priority exit tray].

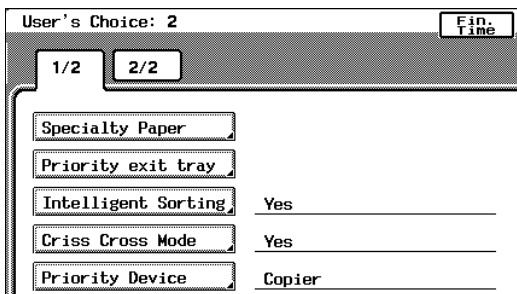

- 4 Select the output tray that you wish to assign to each application.
- 5 Touch [Enter].
- 6 Touch [Fin. Time], and then touch [Fin. Time] again in the screen that appears.

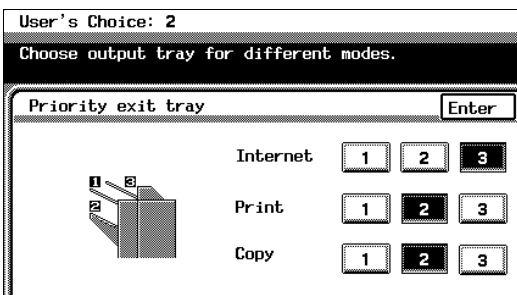

To set the “Intelligent Sorting” function

This function is used to specify if the “Sort” setting or the “Non-Sort” setting is selected automatically for documents loaded into the duplexing document feeder. By setting this function to “Yes”, the “Non-Sort” setting will automatically be selected if a document consisting of only one page is loaded into the duplexing document feeder, and the “Sort” setting will automatically be selected if a document consisting of two or more pages is placed in the duplexing document feeder. (The default setting is [Yes].)

- 1 Press the [Utility] key.
- 2 Touch [User’s Choice: 2].
- 3 Touch [Intelligent Sorting].

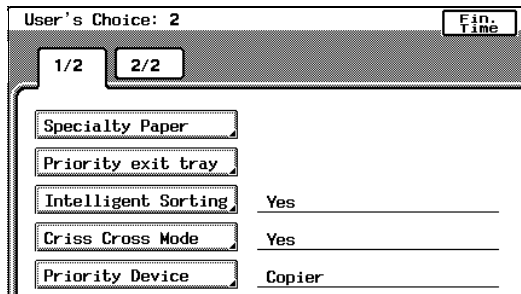

- 4 Select the desired setting.
- 5 Touch [Enter].
- 6 Touch [Fin. Time], and then touch [Fin. Time] again in the screen that appears.

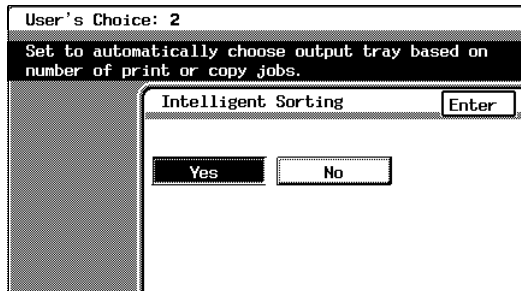

To set the “Criss Cross Mode” function

This function is used to specify how copies are sorted when the “Sort” setting is selected. (The default setting is [Yes].)

For details on crisscross sorting, refer to “Original Documents/Feeding the Document” in the Basic Operations volume.

- 1 Press the [Utility] key.
- 2 Touch [User’s Choice: 2].
- 3 Touch [Criss Cross Mode].

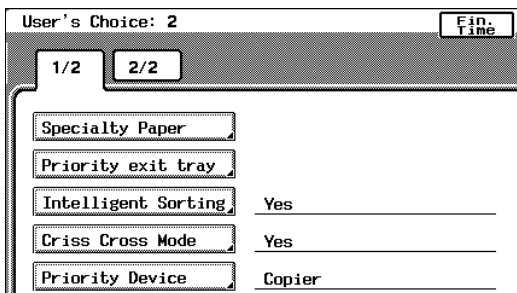

- 4 Select the desired setting.
- 5 Touch [Enter].
- 6 Touch [Fin. Time], and then touch [Fin. Time] again in the screen that appears.

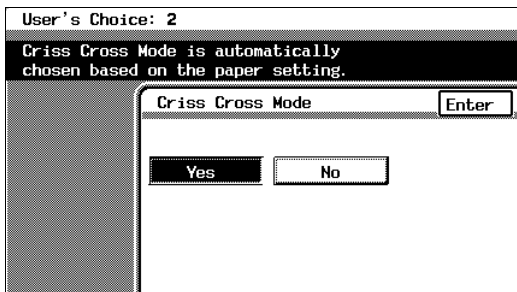

To set the “Priority Device” function

This function is used to specify the print timing for a print job that is received.

Copy jobs and Internet fax print jobs are normally printed as a set. (The default setting is [Copier].)

Copier setting

Print jobs are queued as a job when the data for all pages are received.

Printer setting

Print jobs are queued as a job when the data for the first page is received.

- 1 Press the [Utility] key.
- 2 Touch [User’s Choice: 2].
- 3 Touch [Priority Device].

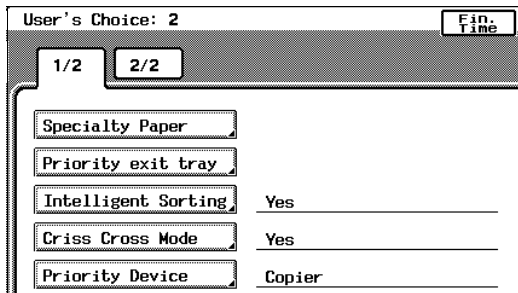

- 4 Select the desired setting.
- 5 Touch [Enter].
- 6 Touch [Fin. Time], and then touch [Fin. Time] again in the screen that appears.

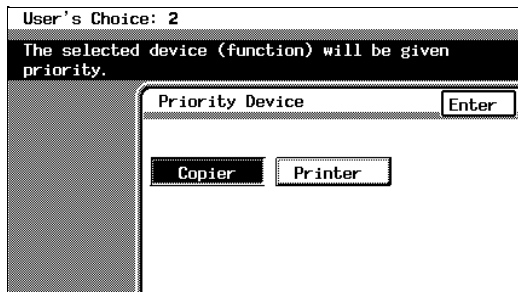



To set the “ACS Judgement Level Adjust.” function

This function is used to adjust the level for detecting a color or black-and-white document with the Color setting “Auto Color”. The detection level can be adjusted to one of 5 settings. (The default setting is [3 (Std.)].)

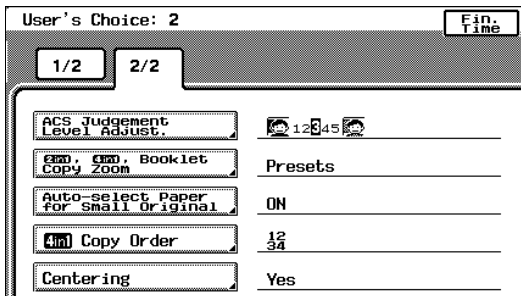
- 1 Press the [Utility] key.
- 2 Touch [User’s Choice: 2].
- 3 Touch [2/2].
- 4 Touch [ACS Judgement Level Adjust.].



- 5 Touch  and  to specify the desired detection level.
- 6 Touch [Enter].
- 7 Touch [Fin. Time], and then touch [Fin. Time] again in the screen that appears.

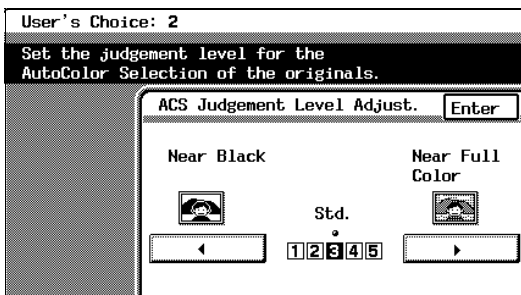

To set the “2in1, 4in1, Booklet Copy Zoom” function

This function is used to specify the zoom ratio for 2in1 copying, 4in1 copying and booklet binding. If this function is set, the specified zoom ratio is automatically applied when any of these Copy settings are selected. (The default setting is [Presets].)

- 1 Press the [Utility] key.
- 2 Touch [User’s Choice: 2].
- 3 Touch [2/2].
- 4 Touch [2in1, 4in1, Booklet Copy Zoom].

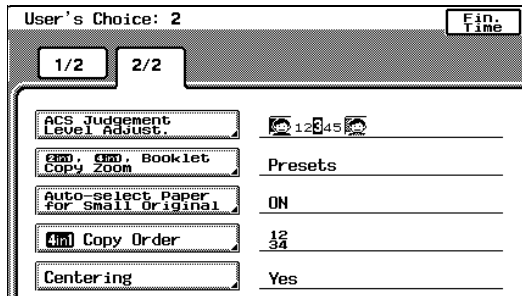

- 5 Select the desired setting.
- 6 Touch [Enter].
- 7 Touch [Fin. Time], and then touch [Fin. Time] again in the screen that appears.

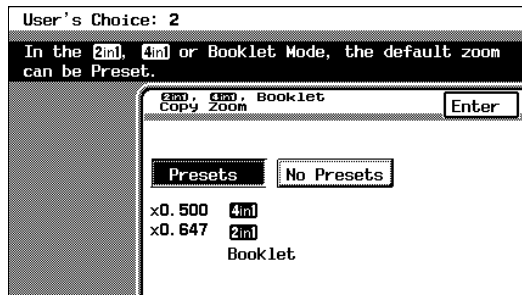

To set the “Auto-select Paper for Small Original” function

This function is used to select whether or not to print documents with a size that is too small and cannot be automatically detected. (The default settings are “ON” and the 1st drawer.)

If this function is set to “Off”, copies cannot be made under either of the following conditions.

- ✓ When the [Start] key is pressed with the Paper setting “Auto Paper” selected, but the size of the document is too small to be detected and the paper cannot be selected
- ✓ When the [Start] key is pressed with the Paper setting “Auto Paper” selected, but no document has been loaded



Tip

If this function is set to “ON”, copies will be made even under the conditions described above.

In this case, since the document size cannot be detected and the paper cannot be automatically selected, the paper (source) must be selected.

- 1 Press the [Utility] key.
- 2 Touch [User’s Choice: 2].
- 3 Touch [2/2].
- 4 Touch [Auto-select Paper for Small Original].

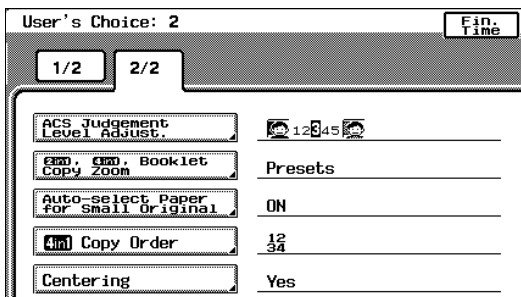

- 5 Select the desired setting.
- 6 If “ON” was selected, select a paper drawer.
- 7 Touch [Enter].
- 8 Touch [Fin. Time], and then touch [Fin. Time] again in the screen that appears.

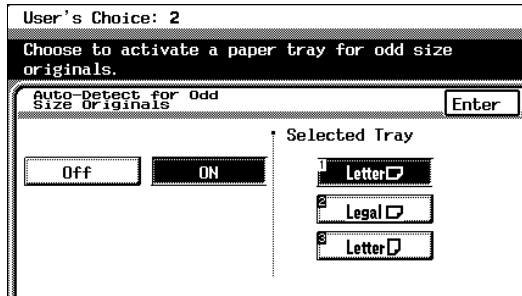

To set the “4in1 Copy Order” function

This function is used to specify the copy order during 4in1 copying. (The default setting is $\begin{bmatrix} 1 & 2 \\ 3 & 4 \end{bmatrix}$.)

- 1 Press the [Utility] key.
- 2 Touch [User’s Choice: 2].
- 3 Touch [2/2].
- 4 Touch [4in1 Copy Order].

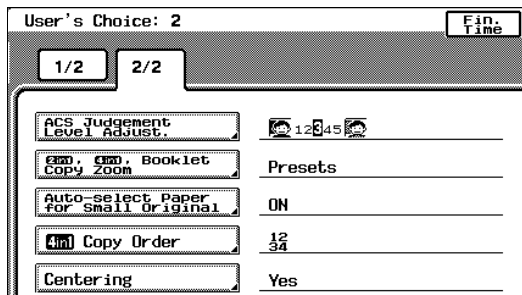

- 5 Select the desired setting.
- 6 Touch [Enter].
- 7 Touch [Fin. Time], and then touch [Fin. Time] again in the screen that appears.

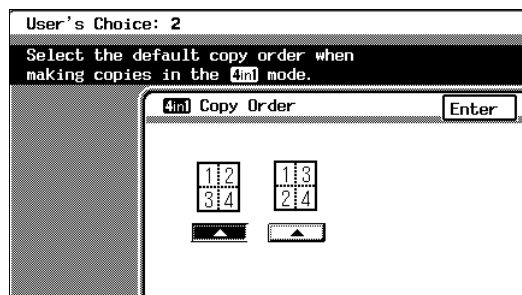

To set the “Centering” function

This function is used to specify the printing position of the image when the document is smaller than the paper. (The default setting is [Yes].)

- 1 Press the [Utility] key.
- 2 Touch [User’s Choice: 2].
- 3 Touch [2/2].
- 4 Touch [Centering].

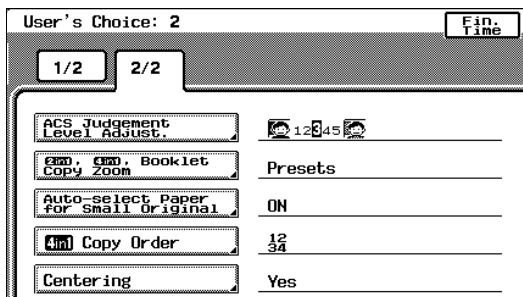

- 5 Select the desired setting.
- 6 Touch [Enter].
- 7 Touch [Fin. Time], and then touch [Fin. Time] again in the screen that appears.

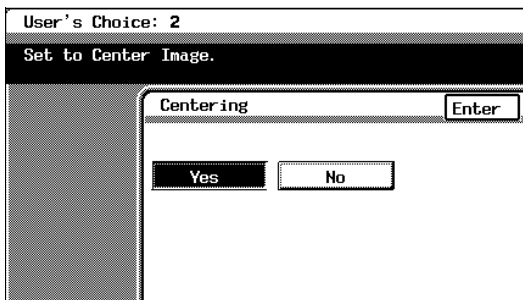

5.3 Viewing Counters (“Meter Count” Function)

The counters, showing the number of the various types of copies that have been made since the copier was installed, can be viewed.

The following counts can be viewed.

Total counters

- Total: Total number of copies and printouts
- Size: Total number of copies and printouts on paper specified as large-size paper
- Duplex Copy: Total number of double-sided copies
- Duplex Print: Total number of double-sided printouts
- Scan: Total number of scans

Black counters

- Copy Total: Total number of black-and-white copies
- Copy Size: Total number of black-and-white copies on paper specified as large-size paper
- Printer Total: Total number of black-and-white printouts
- Printer Size: Total number of black-and-white printouts on paper specified as large-size paper
- Copy+Printer: Total number of black-and-white copies and printouts

Full Color counters

- Copy Total: Total number of full-color copies
- Copy Size: Total number of full-color copies on paper specified as large-size paper
- Printer Total: Total number of full-color printouts
- Printer Size: Total number of full-color printouts on paper specified as large-size paper
- Copy+Printer: Total number of full-color copies and printouts

Mono Color counters

- Copy Total: Total number of monotone copies
- Copy Size: Total number of monotone copies on paper specified as large-size paper

- 1 Press the [Utility] key.
- 2 Touch [Meter Count].
- 3 Select the desired color mode. The counters are displayed.
- 4 To print the list of counters, touch [Print], and then press the [Start] key.
The list of counters is printed.

Utility		Fin. Time	
Meter Count	Print	Black	Full Color
		Full Color	Mono Color
Total	0	Copy	Printer
Size	0	0	0
Duplex Copy	0	0	0
Duplex Print	0	Copy+Printer	0
Scan	0		

*The lists are only printed in English.

- 5 Touch [Cancel].
- 6 Touch [Fin. Time].

5.4 Viewing Part Maintenance Levels (“Unit life indicator” Function)

The level of use for the various supplies and parts can be checked.

- 1 Press the [Utility] key.
- 2 Touch [Unit life indicator].
- 3 Graphs showing the maintenance levels for the various parts and supplies are displayed.

The screenshot shows a screen titled "unit life indicator" with a "Fin. Time" button in the top right corner. The main content area is divided into two columns of input fields:

Imaging Unit		Fusing Unit	
(C)	<input type="text"/>	<input type="text"/>	
(M)	<input type="text"/>	Image Transfer Roller Unit	<input type="text"/>
(Y)	<input type="text"/>	Image Transfer Belt Unit	<input type="text"/>
(Bk)	<input type="text"/>		
Paper Ozone Filter	<input type="text"/>	Dust Remover / Filter	<input type="text"/>

A "Print" button is located in the bottom right corner of the screen.

- 4 To print the maintenance levels for the copier, touch [Print], and then press the [Start] key.

The list of maintenance levels are printed.

*The list is only printed in English.

- 5 Touch [Cancel].
- 6 Touch [Fin. Time].

5.5 Administrator Mode Operations

The Administrator mode allows the use of the copier to be controlled. When this mode is selected, a screen appears, indicating that the administrator access code must be entered.

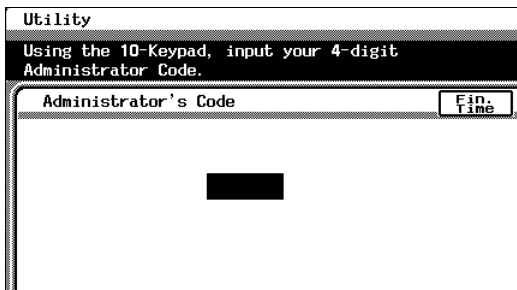

When the administrator access code is entered, the following screen appears.

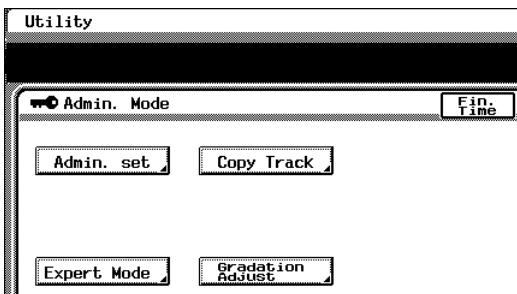

Admin. set (Refer to p. 5-36)

- These functions allow you to specify the amount of the top edge of the image that is erased, the Shut off mode, the size of over size paper and the language.

Copy Track (Refer to p. 5-60)

- These functions allow you to restrict the number of copies possible for each account.

Expert Mode (Refer to p. 5-40)

- In the Expert mode, you can make various expert adjustments, such as color shift corrections and print area adjustments.

Gradation Adjust (Refer to p. 5-56)

- This function is used to adjust the gradation levels of images.

To set the “Top Erase” function

This function is used to set the amount of loss at the edge of the original. This amount is erased during printing. (The default setting is [5 mm].)

- 1 Press the [Utility] key.
- 2 Touch [Admin. Mode].
- 3 Using the keypad, enter the administrator access code.
- 4 Touch [Admin. set].
- 5 Touch [Top Erase].

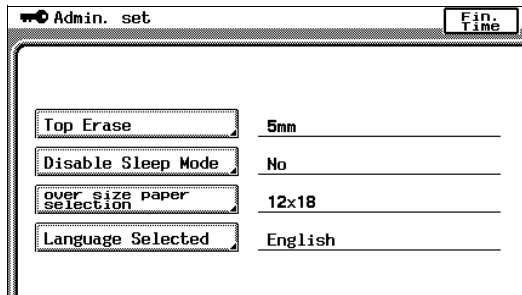

- 6 Select the desired setting.

- 7 Touch [Enter].

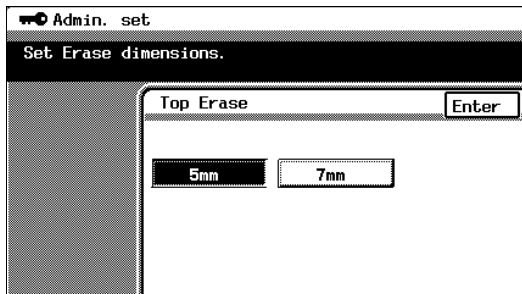

- 8 Touch [Fin. Time] again in the next three screens that appear.

To set the “Disable Sleep Mode” function

This function is used to disable the Sleep mode. (The default setting is [No].)

Setting this function to “Yes” allows you to disable the Sleep mode completely using the “Sleep” function available through the User’s Choice: 1 screen.

For details on the Sleep mode, refer to “Original Documents/Feeding the Document” in the Basic Operations volume.

For more details on setting the “Sleep” function, refer to “Specifying Default Settings (“User’s Choice” Functions)” (page 5-7).

- 1 Press the [Utility] key.
- 2 Touch [Admin. Mode].
- 3 Using the keypad, enter the administrator access code.
- 4 Touch [Admin. set].
- 5 Touch [Disable Sleep Mode].

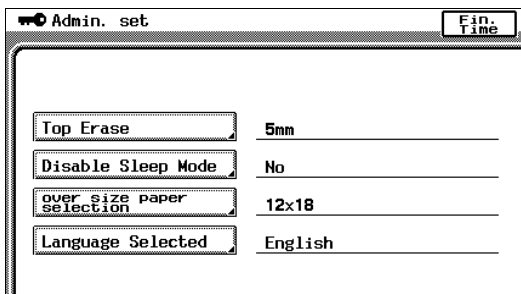

- 6 Touch [Yes].
- 7 Touch [Enter].
- 8 Touch [Fin. Time] again in the next three screens that appear.

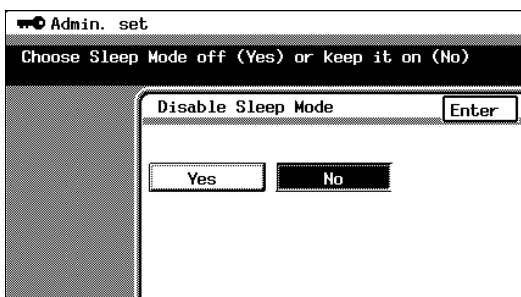

To set the “over size paper selection” function

This function is used to set the paper size for Over sized paper.
(The default setting is [12 × 18].)

- 1 Press the [Utility] key.
- 2 Touch [Admin. Mode].
- 3 Using the keypad, enter the administrator access code.
- 4 Touch [Admin. set].
- 5 Touch [over size paper selection].

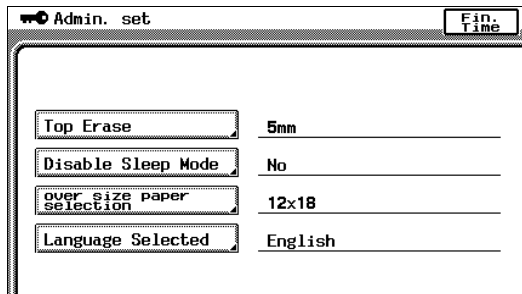

- 6 Select the desired setting.
- 7 Touch [Enter].
- 8 Touch [Fin. Time] again in the next three screens that appear.

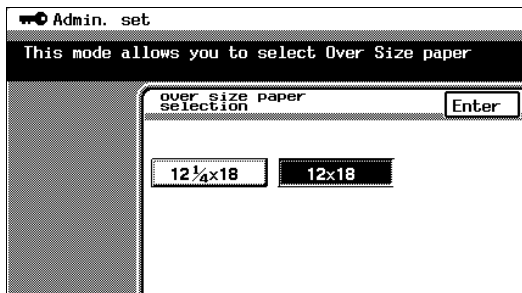

To set the “Language Selected” function

This function is used to change the display language for the touch panel.
(The default setting is [English].)

- 1 Press the [Utility] key.
- 2 Touch [Admin. Mode].
- 3 Using the keypad, enter the administrator access code.
- 4 Touch [Admin. set].
- 5 Touch [Language Selected].

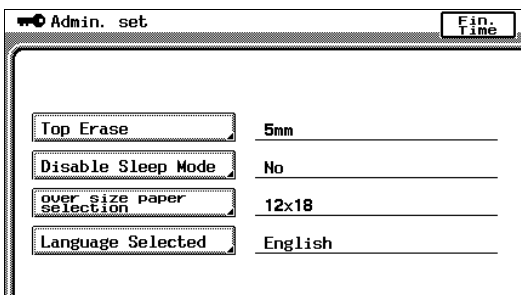

- 6 Select the desired language.
- 7 Touch [Enter].
- 8 Touch [Fin. Time], and then touch [Fin. Time] again in the screen that appears.

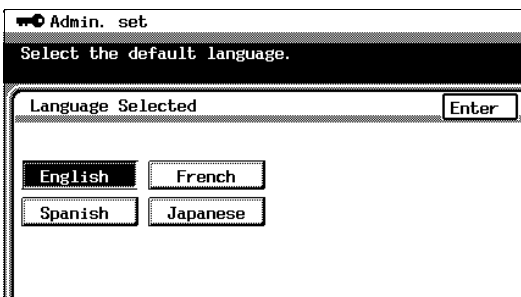

Specifying Expert Mode functions

In the Expert mode, various print image adjustments can be selected.

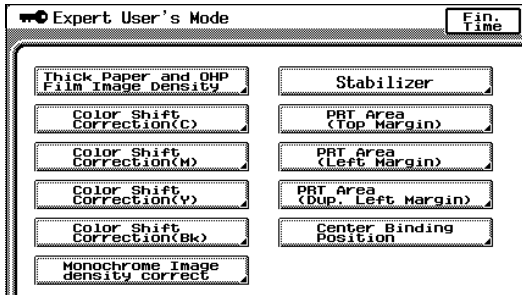

Thick Paper and OHP Film Image Density

(Refer to p. 5-41)

- This function allows the density of the image printed on thick paper to be adjusted.

Color Shift Correction(C)

(Refer to p. 5-42)

- These functions are used to make fine adjustments in the color shift of the printed image.

Monochrome Image density correct

(Refer to p. 5-46)

- This function is used to make adjustments to the printed image of black-and-white copies. (This function is only available on the CF2002.)

Stabilizer

(Refer to p. 5-47)

- This function is used to perform image stabilization.

PRT Area (Top Margin)

(Refer to p. 5-47)

- These functions are used to make fine adjustments to the print area margins of a printed image.

Center Binding Position

(Refer to p. 5-54)



- This function is used to make fine adjustments to the center stapling position and the folding position when binding.

To set the “Thick Paper and OHP Film Image Density” function

This function allows the density of the image printed on thick paper and overhead projector transparencies to be adjusted. (The default settings are [the standard settings (middle settings)].)

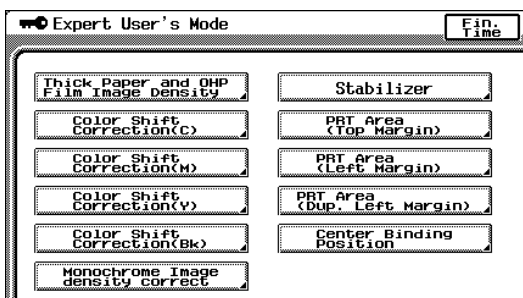
- 1 Press the [Utility] key.
- 2 Touch [Admin. Mode].
- 3 Using the keypad, enter the administrator access code.
- 4 Touch [Expert Mode].
- 5 Touch [Thick Paper and OHP Film Image Density].



- 6 Touch  and  to adjust the image density.
- 7 Touch [Enter].
- 8 Touch [Fin. Time] again in the next three screens that appear.

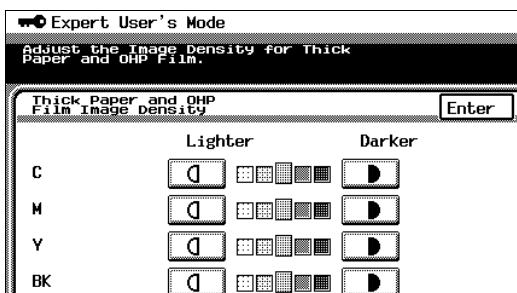

To adjust the color shifts manually

If a difference can be seen between the original document and the copy, fine adjustments in the color shift can be made.

The procedure with 11 × 17-size paper loaded into the 1st drawer is described below.

- 1 Load 11 × 17-size paper into the 1st drawer.
- 2 Press the [Utility] key.
- 3 Touch [Admin. Mode].
- 4 Using the keypad, enter the administrator access code.
- 5 Touch [Expert Mode].
- 6 Touch [Color Shift Correction(Bk)].

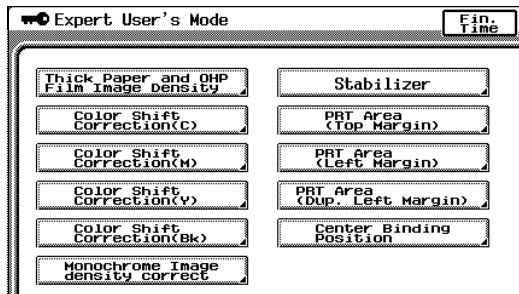

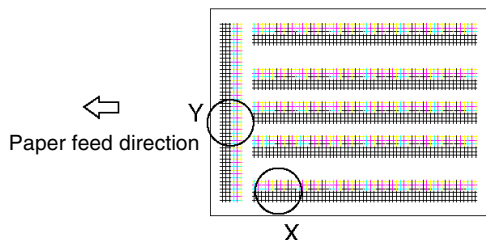
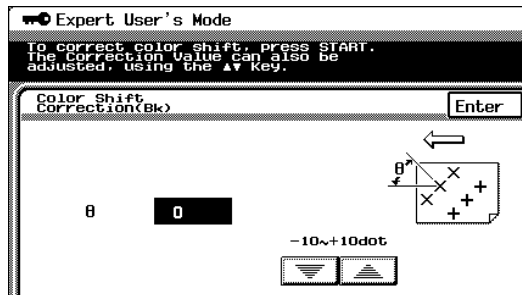

- 7 Press the [Start] key.

The automatic color shift adjustment procedure begins, and the test pattern is printed on the 11 × 17-size paper.

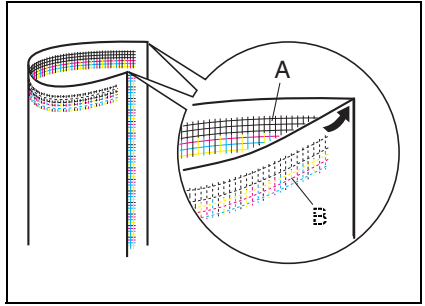

- 8 Fold the paper in half while aligning the corners of the printed test pattern.



- 9 If horizontal lines A and B are angled as shown at the right, touch  to specify the desired negative adjustment for θ (between -1 dot and -10 dots).

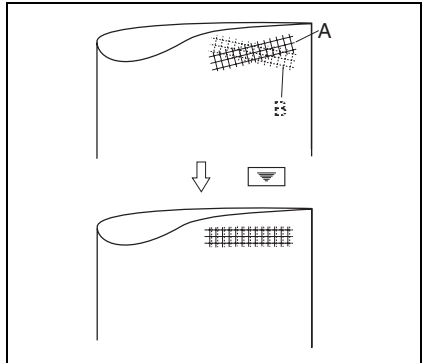

- 10 If horizontal lines A and B are angled as shown at the right, touch  to specify the desired positive adjustment for θ (between +1 dot and +10 dots).

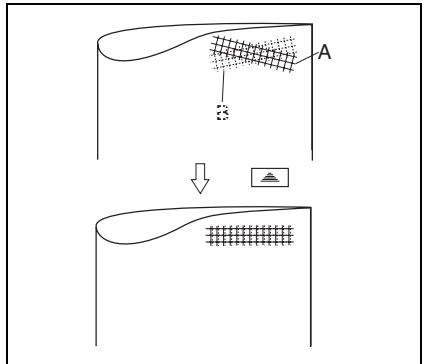

- 11 Press the [Start] key.

The adjusted test pattern is printed on 11 × 17-size paper.

12 Check the print result. If the fold line and the black lines are parallel, skip to step 13.

- If more adjustment is necessary, return to step 7 and repeat the adjustment procedure.

13 Touch [Enter]. The Expert User's Mode screen appears again.

14 Touch [Color Shift Correction(C)].

15 Press the [Start] key.

The automatic color shift adjustment procedure begins, and the test pattern is printed on the 11 × 17-size paper.

16 Check the distance from the reference line of the black lines to the cyan lines in the test pattern along the X and Y directions.

- If there is no shift in the reference line, skip to step 23.

17 If the lines are shifted as shown at the right, touch  to specify the desired negative adjustment for "X" (between -1 dot and -6 dots).

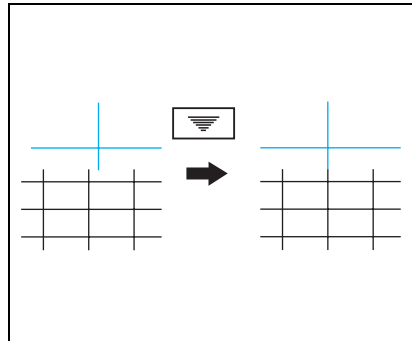

18 If the lines are shifted as shown at the right, touch  to specify the desired positive adjustment for "X" (between +1 dot and +6 dots).

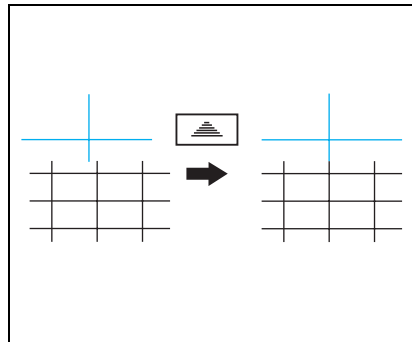

- 19** If the lines are shifted as shown at the right, touch [Y], and then touch  to specify the desired negative adjustment for “Y” (between -1 dot and -6 dots).

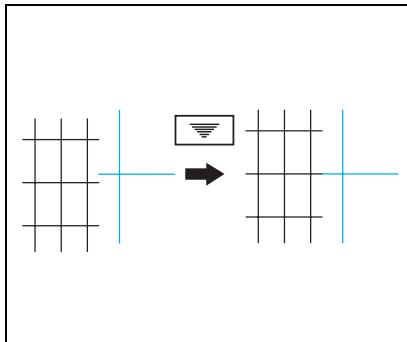

- 20** If the lines are shifted as shown at the right, touch  to specify the desired positive adjustment for “Y” (between +1 dot and +6 dots).

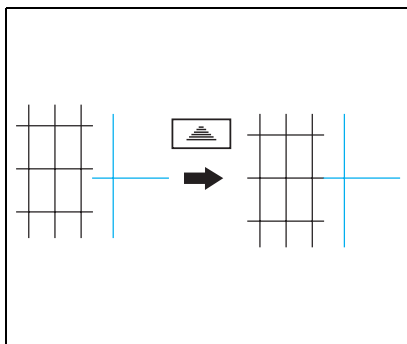



- 21** Press the [Start] key. The adjusted test pattern is printed on 11 × 17-size paper.
- 22** Check the print result. If the distance between the reference line of the black lines and the cyan lines is adjusted to 0, skip to step 23.
- If more adjustment is necessary, return to step 14 and repeat the adjustment procedure.
- 23** Touch [Enter]. The Expert User’s Mode screen appears again.
- 24** Touch [Color Shift Correction(M)]. Repeat the procedure for adjusting the cyan shift (steps 13 to 23) to adjust the magenta shift.
- 25** Touch [Color Shift Correction(Y)] and repeat the same procedure for the yellow shift.
- 26** Touch [Enter].
The Expert User’s Mode screen appears again.
- 27** Touch [Fin. Time] again in the next three screens that appear.

To set the “Monochrome Image density correct” function

This function allows the image density of black-and-white copies to be adjusted. (This function is only available on the CF2002.) (The default setting is [the standard setting (middle setting)].)

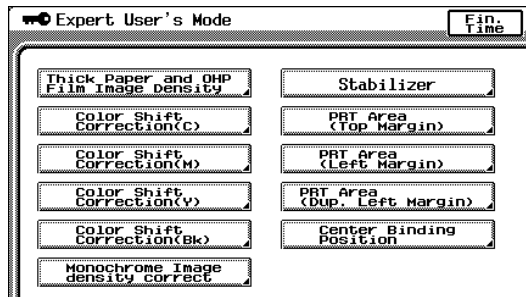
- 1 Press the [Utility] key.
- 2 Touch [Admin. Mode].
- 3 Using the keypad, enter the administrator access code.
- 4 Touch [Expert Mode].
- 5 Touch [Monochrome Image density correct].



- 6 Touch  and  to adjust the image density.
- 7 Touch [Enter].
- 8 Touch [Fin. Time] in the next three screens that appear.

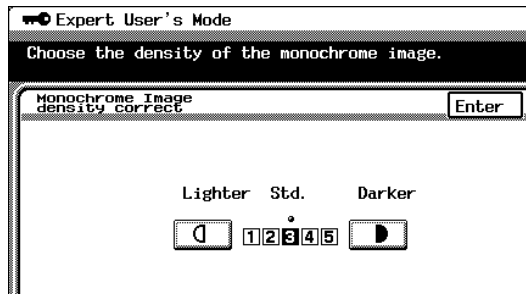

To set the “Stabilizer” function

If the image is incorrect, even after the gradation levels have been adjusted, set the “Stabilizer” function, available on the Admin. Mode screen.

For details on adjusting the gradation levels, refer to “To set the “Gradation Adjust” function” (p. 5-56).

Setting the “PRT Area” Functions

This function is used to adjust the image print position from the edge of the paper.

There are three “PRT Area” margin functions:



(Refer to p. 5-47)

- This function adjusts the starting print position at the leading edge of the paper (with regard to the paper feed direction).



(Refer to p. 5-50)

- This function adjusts the starting print position (with regard to the paper feed direction) from the left edge of the paper.



(Refer to p. 5-52)

- This function adjusts the starting print position at the left edge of the paper for the second side of a double-sided copy.

To set the “PRT Area (Top Margin)” function

The top margin of the printing area can be adjusted for each paper type.

The procedure described below is for 11” × 17” paper.



Note

The top margin of the print area is adjusted during manufacturing of the copier. Normally, the top margin will not need to be adjusted.

- 1 Load 11 × 17-size paper of the desired type into the 1st drawer.
- 2 Turn the media type selection dial to the setting for the type of paper loaded.
- 3 Press the [Utility] key.
- 4 Touch [Admin. Mode].
- 5 Using the keypad, enter the administrator access code.
- 6 Touch [Expert Mode].
- 7 Touch [PRT Area (Top Margin)].

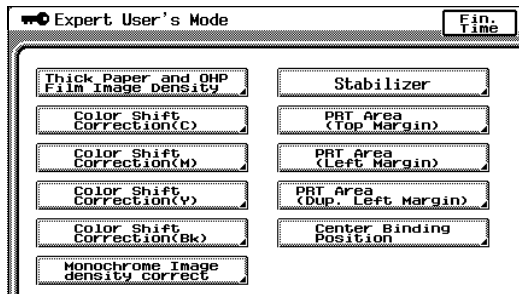
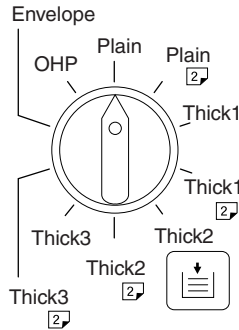

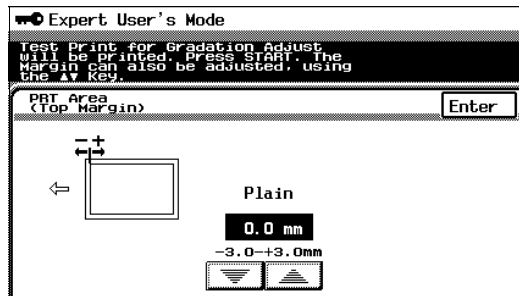

- 8 Press the [Start] key. The test pattern is printed on the 11 × 17-size paper.

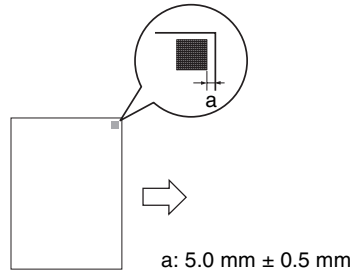

- 9 Check that the top margin of the test pattern is between 4.5 mm and 5.5 mm. If the top margin is within the specified range, skip to step 14.



- 10 If the top margin is less than 4.5 mm, touch  to specify the desired positive adjustment (between +0.1 mm and +3.0 mm).
- 11 If the top margin is more than 5.5 mm, touch  to specify the desired negative adjustment (between -0.1 mm and -3.0 mm).
- 12 Press the [Start] key. The adjusted test pattern is printed on 11 × 17-size paper.
- 13 Check the print result to make sure that the top margin is adjusted to between 4.5 mm and 5.5 mm.
- If more adjustment is necessary, return to step 8 and repeat the adjustment procedure.
- 14 Touch [Enter].
- 15 Touch [Fin. Time] again in the next three screens that appear.

To set the “PRT Area (Left Margin)” function

The left margin of the printing area can be adjusted for each paper drawer. The procedure with 11 × 17-size paper loaded into the 1st drawer is described below.



Note

The top margin of the print area is adjusted during manufacturing of the copier. Normally, the top margin will not need to be adjusted.

- 1 Load 11 × 17-size paper into the 1st drawer.
- 2 Press the [Utility] key.
- 3 Touch [Admin. Mode].
- 4 Using the keypad, enter the administrator access code.
- 5 Touch [Expert Mode].
- 6 Touch [PRT Area (Left Margin)].

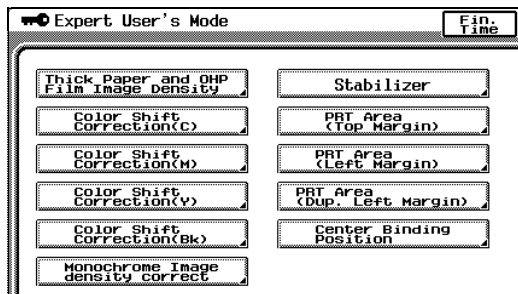

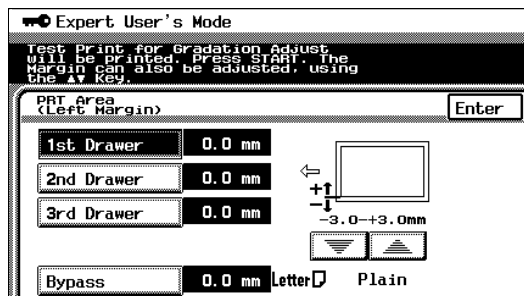

- 7 Touch [1st Drawer].
- 8 Press the [Start] key. The test pattern is printed on the 11 × 17-size paper.

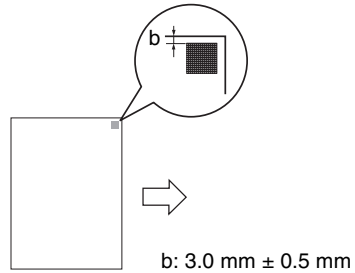

- 9 Check that the left margin of the test pattern is between 2.5 mm and 3.5 mm. If the left margin is within the specified range, skip to step 14.



- 10 If the left margin is less than 2.5 mm, touch  to specify the desired positive adjustment (between +0.1 mm and +3.0 mm).
- 11 If the left margin is more than 3.5 mm, touch  to specify the desired negative adjustment (between -0.1 mm and -3.0 mm).
- 12 Press the [Start] key. The adjusted test pattern is printed on 11 × 17-size paper.
- 13 Check the print result to make sure that the left margin is adjusted to between 2.5 mm and 3.5 mm.
- If more adjustment is necessary, return to step 8 and repeat the adjustment procedure.
- 14 Touch [Enter].
- 15 Touch [Fin. Time] again in the next three screens that appear.

To set the “PRT Area (Dup. Left Margin)” function

The left margin of the printing area in double-sided copies can be adjusted for each paper drawer.

The procedure with 11 × 17-size paper loaded into the 1st drawer is described below.



Note

The top margin of the print area is adjusted during manufacturing of the copier. Normally, the top margin will not need to be adjusted.

- 1 Load 11 × 17-size paper into the 1st drawer.
- 2 Press the [Utility] key.
- 3 Touch [Admin. Mode].
- 4 Using the keypad, enter the administrator access code.
- 5 Touch [Expert Mode].
- 6 Touch [PRT Area (Dup. Left Margin)].

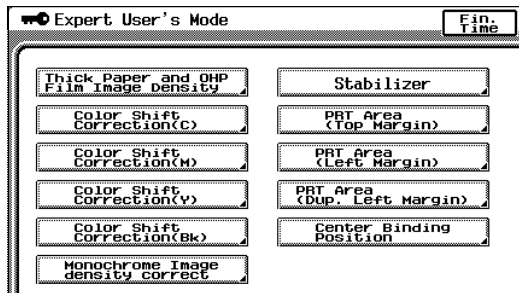

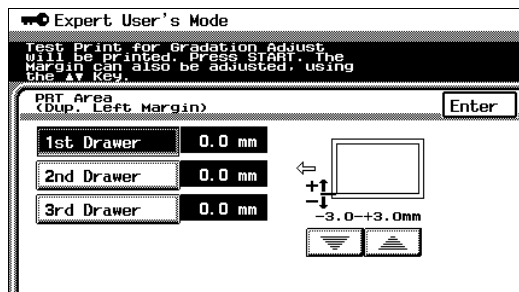

- 7 Touch [1st Drawer].
- 8 Press the [Start] key.
The test pattern is printed on 11 × 17-size paper.

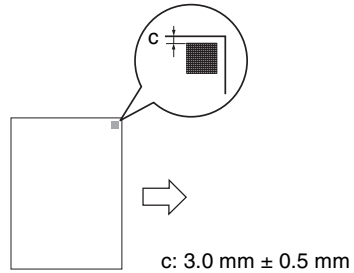

- 9** Check that the left margin of the test pattern for the second side is between 2.5 mm and 3.5 mm.

If the left margin for the second side is within the specified range, skip to step 14.



- 10** If the left margin for the second side is less than 2.5 mm, touch  to specify the desired positive adjustment (between +0.1 mm and +3.0 mm).
- 11** If the left margin for the second side is more than 3.5 mm, touch  to specify the desired negative adjustment (between -0.1 mm and -3.0 mm).
- 12** Press the [Start] key.
- The adjusted test pattern is printed on 11 × 17-size paper.
- 13** Check the print result to make sure that the left margin for the second side is adjusted to between 2.5 mm and 3.5 mm.
- If more adjustment is necessary, return to step 8 and repeat the adjustment procedure.
- 14** Touch [Enter].
- 15** Touch [Fin. Time] again in the next three screens that appear.

To set the “Center Binding Position” function

This function is used to make fine adjustments to the center stapling position and the folding position when binding. (The default setting is [0 mm].)

Use the “Booklet Creation” setting to make a copy sample.

For details on booklet-binding, refer to “Original Documents/Feeding the Document” in the Basic Operations volume.

- 1 Press the [Utility] key.
- 2 Touch [Admin. Mode].
- 3 Using the keypad, enter the administrator access code.
- 4 Touch [Expert Mode].
- 5 Touch [Center Binding Position].

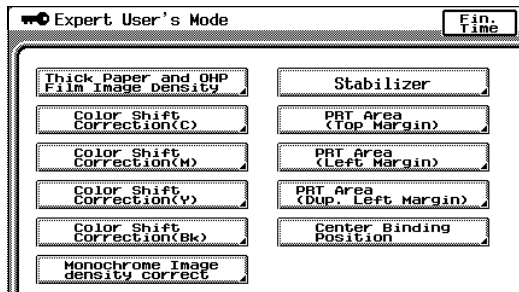

- 6 Compare the width of the left pages of the copy sample with the width of the right pages.

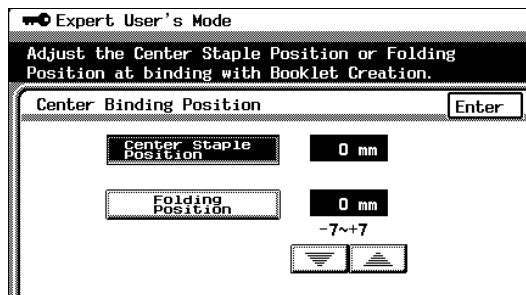

- 7 If the staple position is too far to the left of the center of the paper, touch  to specify the desired positive adjustment (between +1 mm and +7 mm).

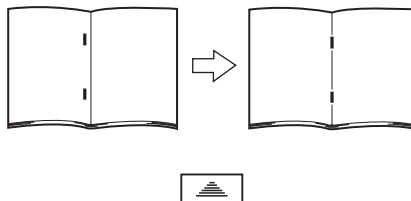

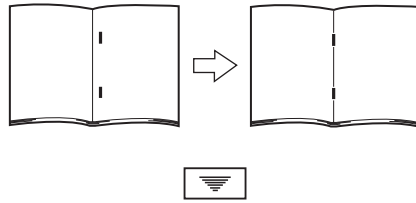

- 8 If the staple position is too far to the right of the center of the paper, touch  to specify the desired negative adjustment (between -1 mm and -7 mm).

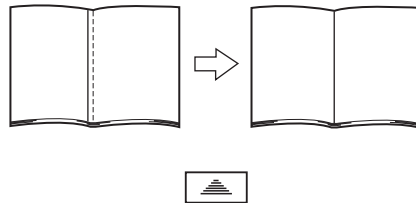

- 9 Touch [Folding Position].

- 10 If the folding position is shifted to the left, touch  to specify the desired positive adjustment (between +1 mm and +7 mm).



- 11 If the folding position is shifted to the right, touch  to specify the desired negative adjustment (between -1 mm and -7 mm).

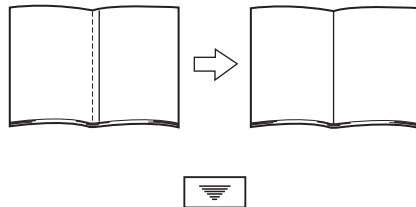

- 12 Touch [Enter].

- 13 Touch [Fin. Time] in the next three screens that appear.

- 14 Use the “Booklet Creation” setting to make another copy sample.

- 15 Check the print result.

- If more adjustment is necessary, return to step 1 and repeat the adjustment procedure.

To set the “Gradation Adjust” function

The color gradation levels can be adjusted if they are incorrect.

After replacing the Imaging Unit, be sure to perform the “Gradation Adjust”, following the procedures below.

- 1 Load 11 × 17-size paper into the 1st drawer.
 - A4 C, A3 or Letter C can be loaded instead.
- 2 Press the [Utility] key.
- 3 Touch [Admin. Mode].
- 4 Using the keypad, enter the administrator access code.
- 5 Touch [Gradation Adjust]. The Gradation Adjust screen appears.

- 6 Press the [Start] key.
A test pattern is printed.

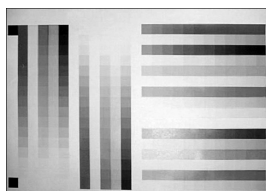
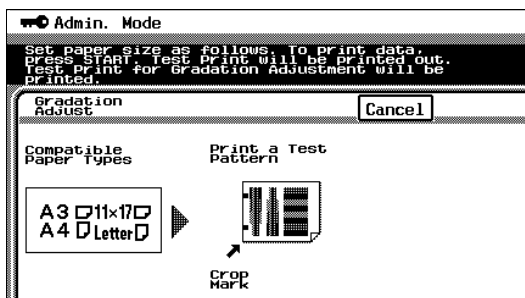

- 7 After the test pattern is printed, the screen changes, as shown at the right.

- 8 Place the printed test pattern on the original glass with the edge with the printed crop marks aligned along the document scale.

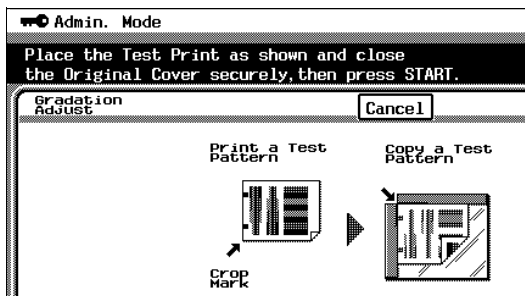

- 9 Place 10 more sheets of blank paper of the same size on top of the printed test pattern page.
- 10 Close the original cover, or the duplexing document feeder if it is installed.
- 11 Press the [Start] key.
The printed test pattern is scanned.
- 12 Based on the scanned image, the gradation levels are automatically adjusted.
After the gradation levels are adjusted, the Admin. Mode screen appears again.
- 13 Repeat steps 5 through 12 three times.
- 14 Touch [Fin. Time], and then touch [Fin. Time] again in the screen that appears.

To set the “Stabilizer” function (if the image is still incorrect, even after the gradation levels have been adjusted)

If the image is incorrect, even after the gradation levels have been adjusted, set the “Stabilizer” function.

The following two modes are available with the “Stabilizer” function.

- Reset And Stabilizer Mode
- Stabilizer Mode

The “Stabilizer” function performs an image stabilization based on past data up to the previous session.

Image stabilization should normally be performed with “Stabilizer Mode” selected.

Select “Reset And Stabilizer Mode” only if the desired effect cannot be attained with the “Stabilizer Mode”.

- 1 Press the [Utility] key.
- 2 Touch [Admin. Mode].
- 3 Using the keypad, enter the administrator access code.
- 4 Touch [Expert Mode].
- 5 Touch [Stabilizer].

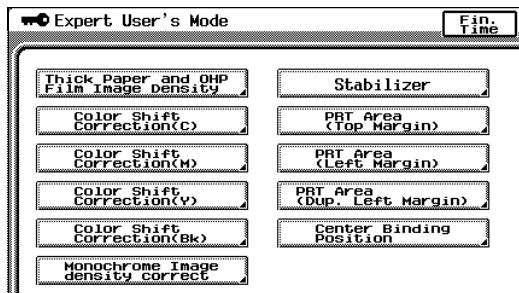

- 6 Press the [Start] key.

The indicator on the [Start] key changes to orange, and the image stabilization operation is performed.

The indicator on the [Start] key changes back to green.

The image stabilization procedure is finished.

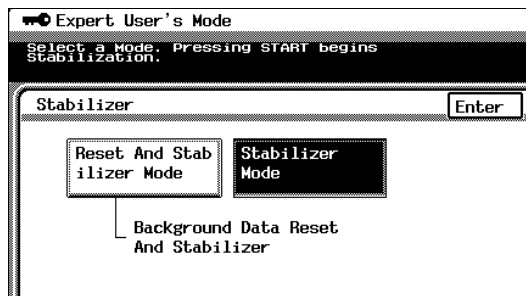

- 7 Touch [Enter].
- 8 Touch [Fin. Time] again in the next three screens that appear.

5.6 Supervising Copier Use (Copy Track Functions)

Setting the Copy Track Functions

These functions are used to control the permissions and the number of copies that can be printed for the account of each user.

The number of copies can be controlled for 99 accounts.

This function is convenient if the copier is used by many people.



Note

The Copy Track functions are for use by the administrator. The Copy Track parameters cannot be set by anyone without knowledge of the administrator access code. For details on the administrator access code, contact your technical representative.

If “Copy Track Mode” is set to “Yes”, only users with an access code for a particular account can use the copier; people without an access code cannot use the copier. In addition, permissions for use can be specified for each account.

The following four Copy Track parameters are available.

- “Total Count” parameter: Counts the total number of copies and printouts
- “Copy Limit” parameter: Limits the number of copies or printouts that can be made; when the limit is reached, no more copies or printouts can be made.
 - Even if a limit is specified, the number of copies and printouts are not limited if “Yes” is not selected for the “Max. # of Prints” parameter on the Copy Track Set screen.
- “Size” parameter: Counts the total number of copies and printouts on paper specified as large-size paper
- “2” parameter: Counts the total number of double-sided copies and printouts

Each of the four parameters listed above can apply to each of the following color modes.

- Total Count: All color modes
- Black: Color setting “Black”
- Full Color: Color setting “Full Color” copy mode
- Mono Color: “Monotone” function

Each of the color modes listed above can apply to each print type listed below.

- Copy + Print
- Copy
- Print

**Note**

The “Copy Track” function and the “Memory Recall” function cannot be used at the same time. In order to use the “Copy Track” function, the “Memory Recall” function on the User’s Choice: 1 screen must be set to “No”.

For details on setting the “Memory Recall” function on the User’s Choice: 1 screen, refer to “To set the “Memory Recall” function” of “Specifying Default Settings (“User’s Choice” Function)” in chapter 5 “Utility Mode Operations”.

Counters

Print Type	Color Mode	Parameter	
Copy + Print	Total Count	Total Count	
		Copy Limit	
		Size	
		2	
	Black	Total Count	
		Copy Limit	
		Size	
	Full Color	Total Count	
		Size	
		Color Limit	
	Mono Color	Total Count	
		Size	
Color Limit			
Copy	Total Count	Total Count	
		Size	
		2	
	Black	Total Count	
		Size	
	Full Color	Total Count	
		Size	
	Mono Color	Total Count	
		Size	
	Print	Total Count	Total Count
			Size
			2
Black		Total Count	
		Size	
Full Color		Total Count	
		Size	

Specifying Account Settings

Permissions and limits for each account can be specified.

Permissions

The permissions in each copy mode for each account can be specified.

- For example, if the “admit to output” parameter for account 001 is set to “Prohibit” for “Color”, the user of account 001 cannot use the Color setting “Full Color” or the “Monotone” function.
- If the “admit to output” parameter is set to “Prohibit” for both “Black” and “Color”, the user cannot print any jobs.

Limits

The maximum number of copies or printouts that can be made by each account can be specified.

- If the “Max. # of Prints” parameter is not set to “Yes”, use of the copier will not be affected when the number of copies reaches the specified limit.

To set the “Copy Track Mode” parameter



Note

If the “Copy Track Mode” setting is changed (to either “Yes” or “No”), all “Copy Track Data” counters are erased.

If you wish to keep a record of the “Copy Track Data” counters, print them out before changing the “Copy Track Mode” setting.

- 1 Press the [Utility] key.
- 2 Touch [Admin. Mode].
- 3 Using the keypad, enter the four-digit administrator access code.

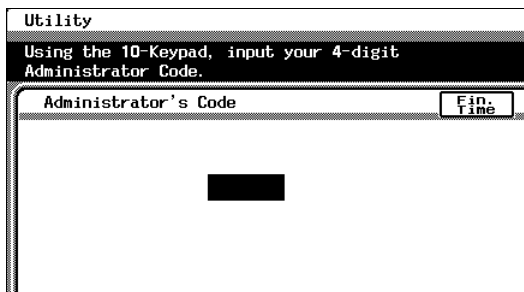

**Note**

The Copy Track functions are for use by the administrator. The Copy Track parameters cannot be set by anyone without knowledge of the administrator access code. For details on the administrator access code, contact your technical representative.

4 Touch [Copy Track].

5 Touch [Copy Track Mode].

The screenshot shows a screen titled "Copy Track" with a "Fin. Time" field in the top right. The main content area contains several data entry fields:

- Copy Track Mode: No
- Copy Track Data / Copy Print
- Copy Track Data / Copy
- Copy Track Data / Print
- Copy Track Set

6 Touch [Yes], and then touch [Enter].

The "Copy Track" mode parameter is set.

7 To cancel the "Copy Track" function, touch [No], and then touch [Enter].

The Initial Data screen appears.

The screenshot shows the "Copy Track" screen with a dialog box titled "Select Copy Track Mode." The dialog box contains a "Copy Track Mode" field with an "Enter" button to its right. Below the field are two buttons: "Yes" and "No".

**Note**

If the "Copy Track Mode" parameter on the "Copy Track" screen is set to "Yes", the "Memory Recall" function on the User's Choice: 1 screen is automatically set to "No". Setting the "Memory Recall" function on the User's Choice: 1 screen to "Yes" automatically changes the "Memory Recall" function to "No".

For details on setting the "Memory Recall" function on the User's Choice: 1 screen, refer to "To set the "Memory Recall" function" of "Specifying Default Settings ("User's Choice" Function)" in chapter 5 "Utility Mode Operations".

- 8 To cancel the Copy Track mode, touch [Yes], and then touch [Enter].

The “Copy Track Data” counters are initialized, and then the “Copy Track” function is canceled.



Note

In order to cancel the “Copy Track” function, the Copy Track mode counters must be initialized.

The Copy Track mode cannot be canceled without the “Copy Track Data” counters being initialized.

- 9 If you do not wish to initialize the “Copy Track Data” counters, touch [No], and then touch [Enter].

The Copy Track mode is not canceled, and the “Copy Track Data” counters are not initialized.

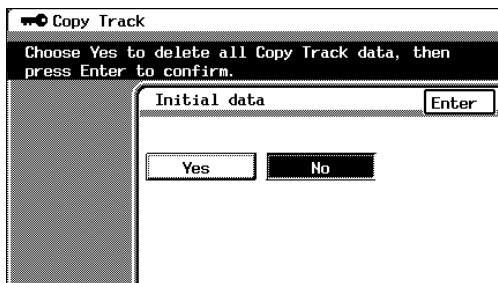

To print a “Copy Track Data” counter



Note

If “Yes” is not selected for the “Copy Track Mode” parameter, no “Copy Track Data” counter can be selected.

- 1 Press the [Utility] key.
- 2 Touch [Admin. Mode].
- 3 Using the keypad, enter the four-digit administrator access code.
- 4 Touch [Copy Track].
- 5 Select the desired “Copy Track Data” counter.

The selected “Copy Track Data” screen appears.

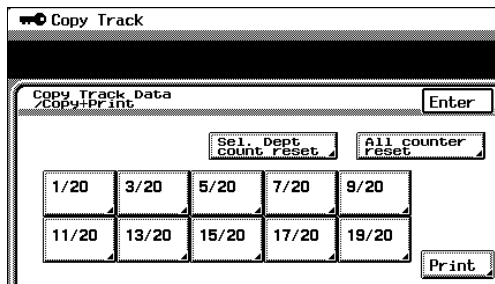

- 6 Touch [Print].
- 7 Load Letter-size paper crosswise into the 1st drawer, and then press the [Start] key.
The icon indicating that data is being sent appears.
- 8 The print job is queued for printing.
The “Copy Track Data” counter is printed.
- 9 Touch [Cancel], and then touch [Enter].
- 10 Touch [Enter]. The Copy Track screen appears again.



To initialize a “Copy Track Mode” counter



Note

If “Yes” is not selected for the “Copy Track Mode” parameter, no “Copy Track Data” counter can be selected.

- 1 Press the [Utility] key.
- 2 Touch [Admin. Mode].
- 3 Using the keypad, enter the four-digit administrator access code.
- 4 Touch [Copy Track].
- 5 Touch [Copy Track Data/Copy + Print].

The “Copy Track Data” screen appears.

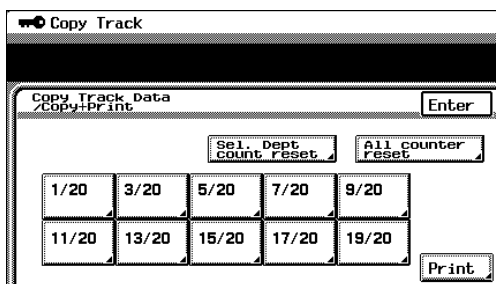

- 6 To initialize the “Copy Track Data” counter for a particular account, touch [Sel. Dept count reset].

A screen appears, allowing you to select the account number.

- 7 Select the 3-digit account number for the desired account.

To initialize the “Copy Track Data” counter for another account, continue selecting account numbers.

- 8 Touch [Clear].

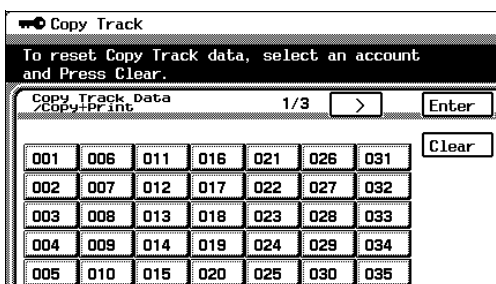

9 Touch [Enter].

- The “Total Count”, “Size” and “2” counters for the selected accounts are initialized.
- The “ID”, “Copy Limit” and “Color Limit” settings are not initialized.

10 To initialize the “Copy Track Data” counter for all accounts, touch [All counter reset].

The Clear All Counters screen appears.

11 Touch [Enter].

The “Copy Track Data” counter for all accounts are initialized.

12 Touch [Enter].

The Copy Track screen appears again.

To specify settings for a “Copy Track Data” counter



Note

If “Yes” is not selected for the “Copy Track Mode” parameter, no “Copy Track Data” counter can be selected.

- 1 Press the [Utility] key.
- 2 Touch [Admin. Mode].
- 3 Using the keypad, enter the four-digit administrator access code.
- 4 Touch [Copy Track].
- 5 Touch [Copy Track Data/Copy+Print].

The Copy Track Data/
Copy+Print screen appears.

- 6 Select the block for the desired account.

- 99 accounts are divided so that there are ten to a block, each of which can be selected.
- For example, touch [1/20] for accounts 001 to 005.

Touching displays accounts 006 through 010.

- 7 Select the ID for the desired account.
- 8 Determine the 4-digit access code for the account.
 - Using the keypad, enter the access code.

- 9 If the access code has been entered incorrectly, press the [C] (clear) key to erase the entered code, and then use the keypad to enter the correct access code.

- 10 Select the limit for the desired account.

- 11 Determine the limit for the account, and then use the keypad to enter the limit value.

The limit can be set between 1 and 999,999 sheets.

The screenshot shows the 'Copy Track' menu with the following data:

No.	ID	Total Count	Copy Limit	Size	2	Total Count
021	----	0	-----	0	0	0
022	----	0	-----	0	0	Black
023	----	0	-----	0	0	Full Color
024	----	0	-----	0	0	Mono Color
025	----	0	-----	0	0	

Navigation: Copy Track Data / Copy Pr. Int. < 5/20 > Enter

- 12 Touch [Black].

- 13 Specify the limit of black-and-white copies/printouts for the account.

Using the keypad, enter the limit value.

- 14 Touch [Full Color].

- 15 Specify the limit of full-color copies/printouts for the account.

- Using the keypad, enter the limit value.
- If the limit for full-color copies/printouts is set, the same limit is automatically set for "Mono Color".

- 16 Touch [Enter].

The specified limits are set.

- 17 Touch [Enter].

The Copy Track screen appears again.

To specify permissions for an account



Note

If “Yes” is not selected for the “Copy Track Mode” parameter, “Copy Track Set” cannot be selected.

- 1 Press the [Utility] key.
- 2 Touch [Admin. Mode].
- 3 Using the keypad, enter the four-digit administrator access code.
- 4 Touch [Copy Track].
- 5 Touch [Copy Track Set].
- 6 Select the block for the desired account.
 - 99 accounts are divided so that there are ten to a block, each of which can be selected.
 - For example, select [1/20] for accounts 001 to 005.

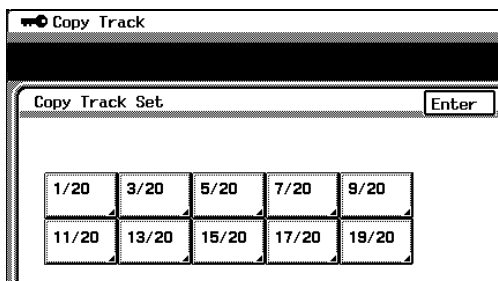

- 7 To cancel the permissions for a desired account, touch [Allow] once.

“Allow” changes to “Prohibit”. (Touch [Prohibit] once to change it back to [Allow].)

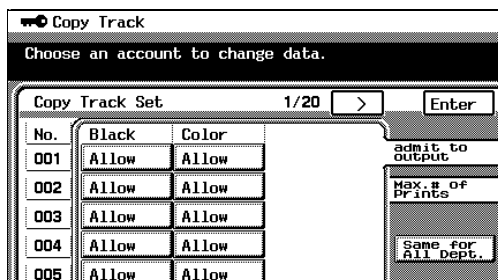

Note

For example, if “Prohibit” appears below “Color” for account 001, the user of account 001 can make copies/printouts using the Color setting “Black”, but cannot use the Color setting “Full Color” or the “Monotone” function.

- 8 To cancel the permissions for all accounts, touch [Same for All Dept.].

Touch [Allow] for account 001 once. The permissions for all accounts are canceled.



Note

For example, if permissions for all accounts are set to “Prohibit” for color printing, the users of all accounts can make copies/printouts using the Color setting “Black”, but cannot use the Color setting “Full Color” or the “Monotone” function.

- 9 Touch [Enter].

The specified permissions are set.

- 10 Touch [Enter].

The Copy Track screen appears again.

To apply the specified limits



Note

If “Yes” is not selected for the “Copy Track Mode” parameter, “Copy Track Set” cannot be selected.

- 1 Press the [Utility] key.
- 2 Touch [Admin. Mode].
- 3 Using the keypad, enter the four-digit administrator access code.
- 4 Touch [Copy Track].
- 5 Touch [Copy Track Set].
- 6 Select the block for the desired account.
 - 99 accounts are divided so that there are ten to a block, each of which can be selected.
 - For example, touch [1/20] for accounts 001 to 005.
- 7 Touch [Max. # of Prints].

Copy Track

Copy Track Set Enter

1/20	3/20	5/20	7/20	9/20
11/20	13/20	15/20	17/20	19/20

- 8 To apply a specified limit, touch “Inactivate” once.

“Inactivate” changes to “Activate”. (Touch [Activate] once to change it back to [Inactivate].)



Note

The total limit for the account and for black and white and color cannot be set at the same time.

Copy Track

Choose an account to change data.

Copy Track Set 1/20 > Enter

No.	Total Count	Black	Color
001	Inactivate	Inactivate	Inactivate
002	Inactivate	Inactivate	Inactivate
003	Inactivate	Inactivate	Inactivate
004	Inactivate	Inactivate	Inactivate
005	Inactivate	Inactivate	Inactivate

admit to output
 Max. # of Prints
 Same for All Dept.

**Note**

For example, if “Color Limit” for “Full Color” is set to 1,000 sheets for account 001, setting “Color” to “Activate” applies the specified limit of 1,000 sheets for full-color printing.

The user of account 001 can only make color copies/prints of 1,000 sheets.

- 9** To apply the limit to all accounts, touch [Same for All Dept.], and then touch [Inactivate] once for account 001.

The specified limits will apply to all accounts.

- 10** Touch [Enter].

The specified limits are applied.

- 11** Touch [Enter].

The Copy Track screen appears again.

***Touch Panel
Messages***

6

6.1 When the Message “CF Toner Cartridge (X) needs to be replaced soon.” Appears

When toner is about to run out, the advance warning message shown below appears.

(As an example, the message for the yellow toner is shown below.)

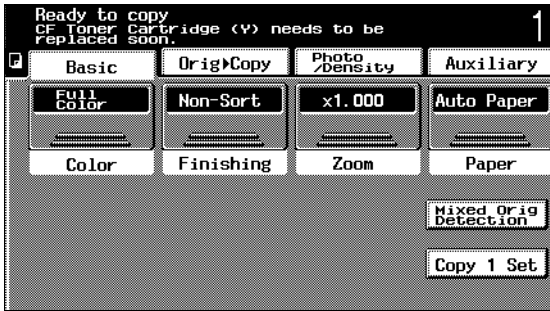

Display in Enlarge Display Mode

If the toner is about to run out,  appears in the screen on the touch panel.

Touch  to display the message shown in the following illustration.

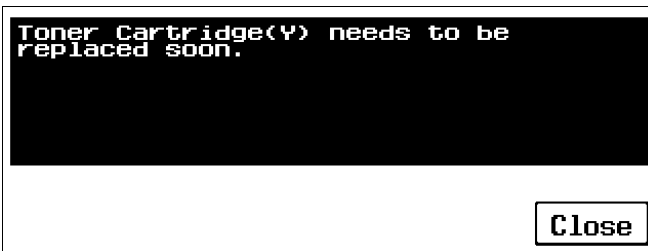

When the message appears, prepare to replace the toner cartridge according to your maintenance agreement.

After the message warning that the toner is almost empty, the message indicating that the toner is empty appears and the copier stops operating.

The number of copies that can be made from the time that the message appears warning that the toner is almost empty until the time that the message appears indicating that the toner is empty differs depending on the specified copy settings.

6.2 When the Message “Replace the CF Toner cartridge” Appears

When the toner is empty, a warning message appears and copies can no longer be made.

As an example, the message indicating that the yellow toner is empty (when replaceable by the user) is shown below.

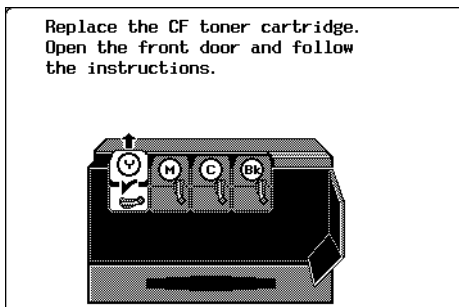

Display in Enlarge Display Mode



When the message appears, replace the toner cartridge according to your maintenance agreement.

For details on replacing the toner cartridges, refer to page 6-5.



WARNING

Handling toner and the toner cartridge

- Do not throw toner or the toner cartridge into a fire. Toner expelled from the fire may cause burns.

**WARNING****Replacing the toner cartridge**

- Do not replace the toner cartridge until the message indicating that it be replaced appears in the touch panel. In addition, do not replace the toner cartridge of any color other than the one indicated in the message on the touch panel.
-

**CAUTION****Be careful not to spill toner inside the copier or get toner on your clothes or hands.**

- If your hands become soiled with toner, immediately wash them with soap and water.
 - If toner gets in your eyes, immediately flush them with water, and then seek professional medical attention.
-

**CAUTION****Used toner cartridges**

- In order to prevent the used toner cartridge from dirtying anything, keep it in the box.
 - Dispose of the used toner cartridge according to your local regulations.
-

To replace the toner cartridge

The procedure for replacing any of the toner cartridges (yellow (Y), magenta (M), cyan (C) or black (Bk)) is the same.

The following procedure describes the replacement of the yellow toner cartridge as an example.



Note

Be careful since the installation location of toner cartridges for other colors is different.

- 1 Open the front door, and then turn counterclockwise the lever for the toner cartridge that you wish to replace.

For example: If the yellow toner is empty, turn the lever for the yellow toner cartridge.

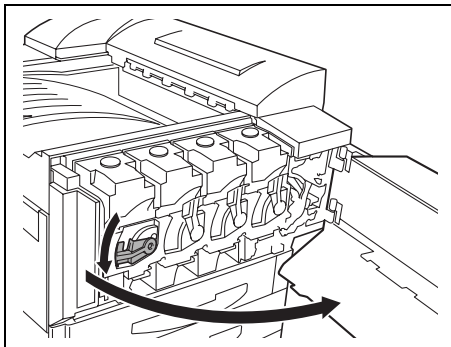

- 2 Pull out the empty toner cartridge.



Note

In order to prevent the used toner cartridge from dirtying anything, keep it in the box.

Dispose of the used toner cartridge according to your local regulations.

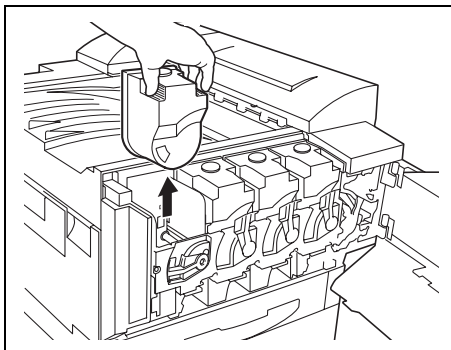

3 Prepare the new toner cartridge.

- Make sure that the color of the toner cartridge is the same color as the lever.



Note

Do not install the toner cartridge of a color different than the one that was removed, otherwise the machine may be damaged.

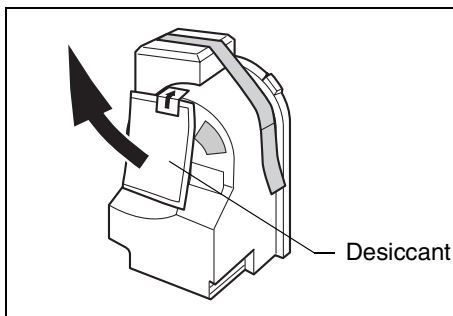

4 Remove the desiccant.

5 Shake the new toner cartridge well.



Note

The toner within the toner cartridge may have become compacted. If it has, be sure to shake the toner cartridge until the toner is mostly broken up before installing the cartridge.

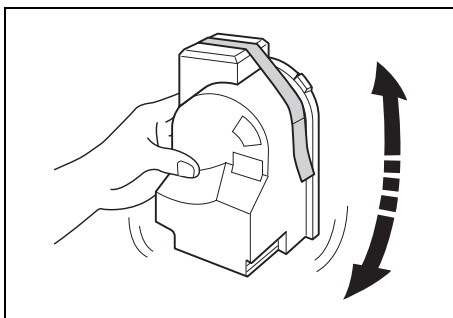

6 Peel off the tape.



Note

Slowly remove the tape attached to the toner cartridge. If the tape is removed with too much force, toner may spurt out.

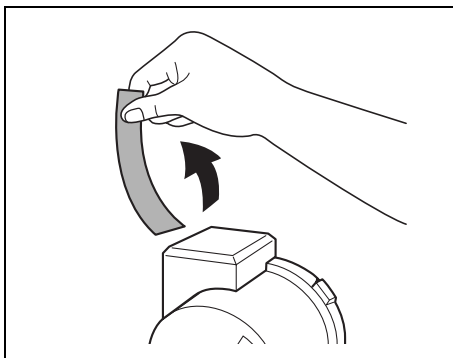

- 7 Remove the protective cap.

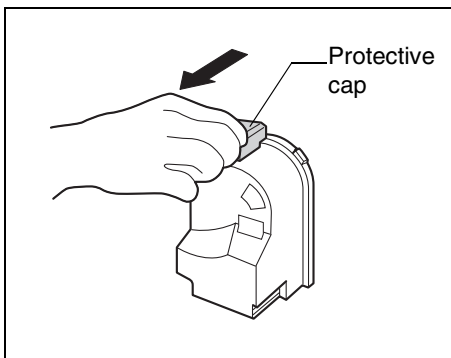

- 8 Position the toner cartridge as shown, and then insert it into its compartment.

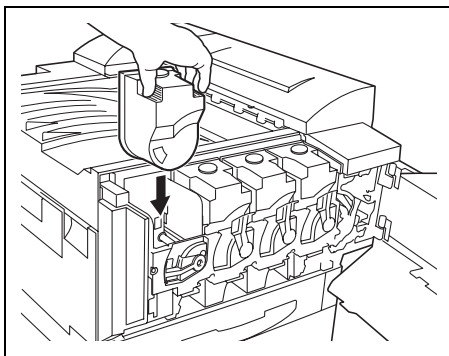

- 9 Turn the lever clockwise.



Note

Make sure that the lever is fully turned, as shown, otherwise the front door cannot be closed.

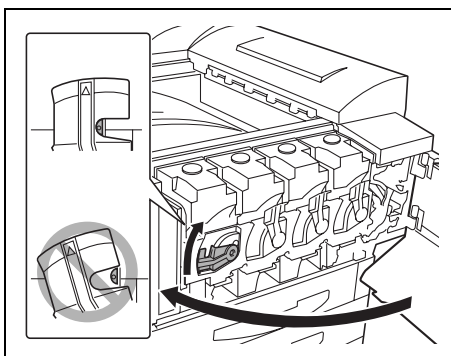

- 10** Slowly pull out the charger-cleaning tool as far as possible, and then slowly push in the charger-cleaning tool as much as possible.

Repeat this step three times.

- 11** Securely insert each charger-cleaning tool, and then close the front door.

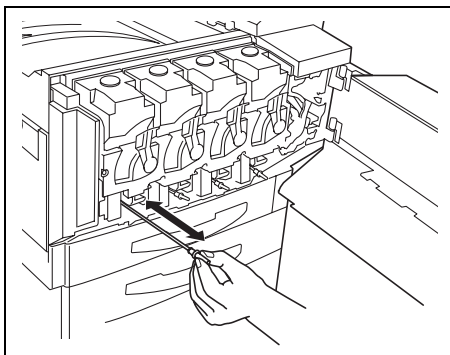

Note

If the door cannot be closed securely, the lever may not be in its correct position. Make sure that the lever is fully turned.



6.3 When the Message “Replace Staple Cartridge.” Appears

When finisher FN-116 or FN-8 is installed and is about to run out of staples, the message shown below appears.

Follow the procedure below to replace the staple cartridge.



Display in Enlarge Display Mode

If the staples are empty,  appears in the screen on the touch panel. Touch  to display the message shown in the following illustration.



Note

Be sure to replace the staple cartridge only after the message appears, otherwise the machine may be damaged.

To replace the staple cartridge for FN-116

- 1 Slide the finisher away from the copier.

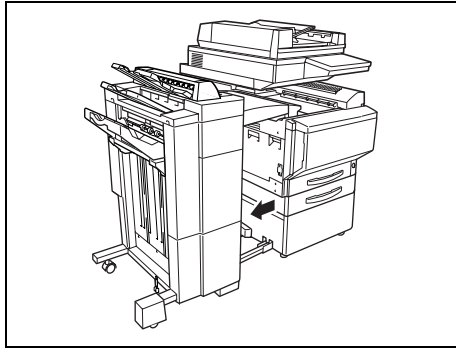

- 2 Turn the dial to the left in order to position the stapler at the center.

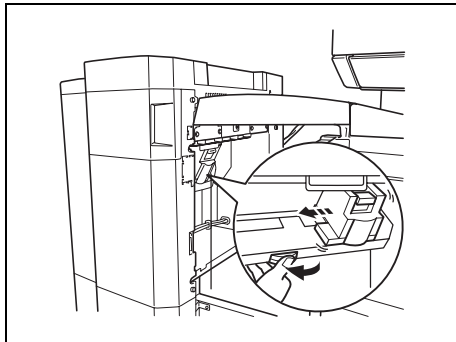

- 3 Pull the staple holder out toward you.

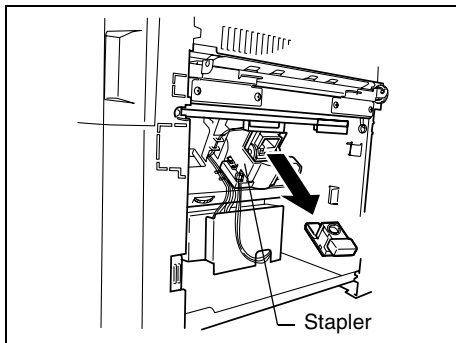

- 4 Remove the empty staple cartridge.

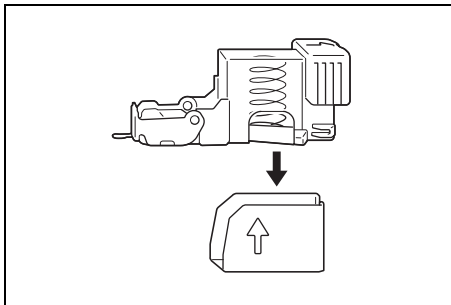

- 5 Insert the new staple cartridge into the staple holder, and then carefully pull out the stopper.

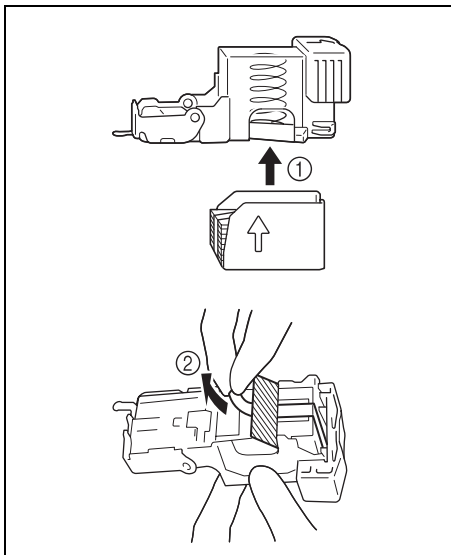

- 6 Insert the refilled staple holder until it locks into place.
- 7 Slide the finisher back against the copier.

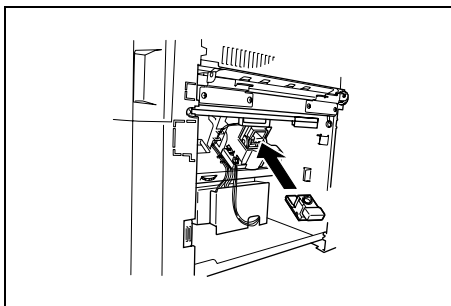

To replace the staple cartridge for FN-8



Note

Be sure to replace the staple cartridge only after the message appears, otherwise the machine may be damaged.

- 1 Open the front door of the finisher.

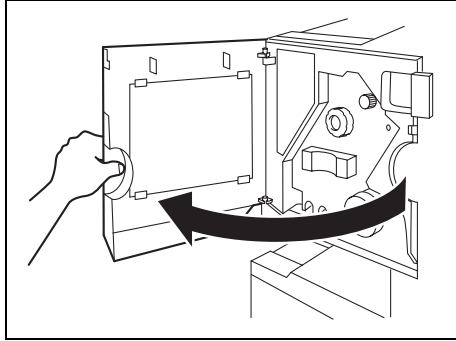

- 2 Turn misfeed-clearing dial ① clockwise until the removal indicator is completely blue.
 - If the dial is turned too far, turn it counterclockwise to adjust it.

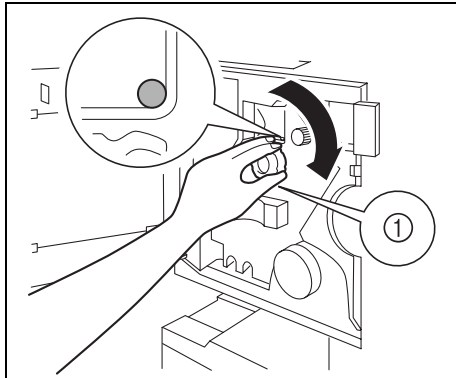

- 3 Slowly pull out the stapler unit as far as possible.

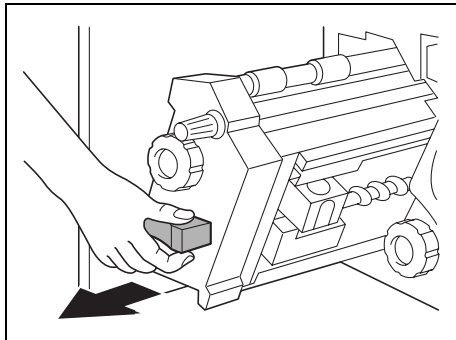

- 4 Turn dial ② clockwise until the staple cartridge moves to a position from where it can be removed.

- If the dial is turned too far, turn it counterclockwise to adjust it.

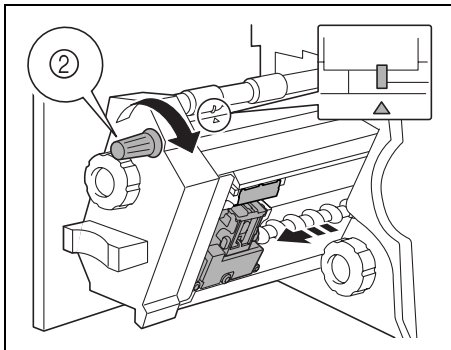

- 5 Grasp both sides of the staple cartridge, lift up the staple cartridge, and then pull it out.

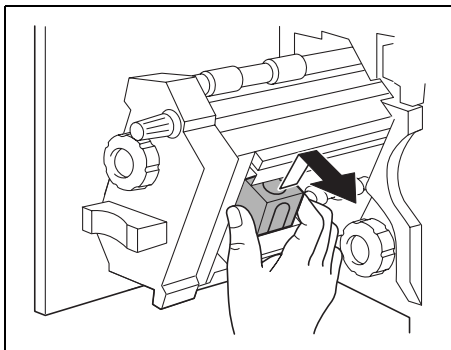

- 6 Press the button marked “PUSH” on the side of the staple cartridge. The staple case is released.

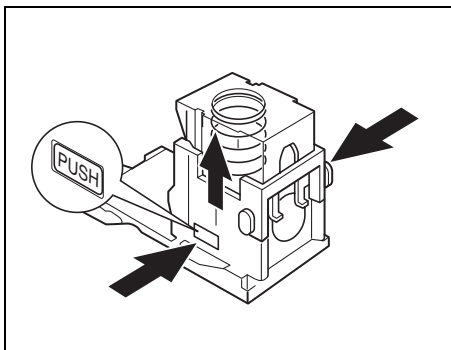

7 Pull up the staple case.

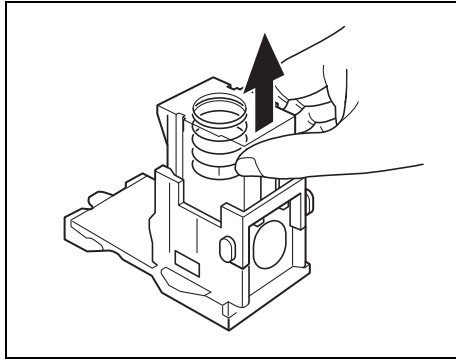

8 Remove the paper holder from the staple case.

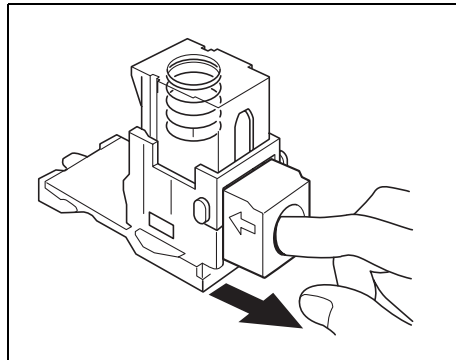

9 Refill the staple case with staples.

- Fully insert the staple case as far as possible.

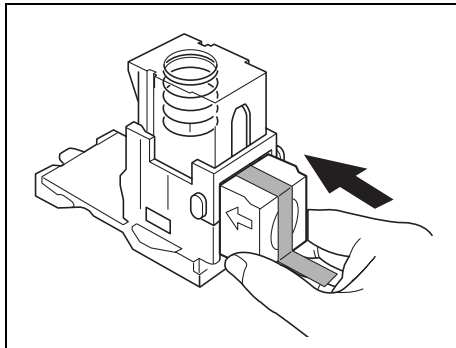

10 Press the staple case down.

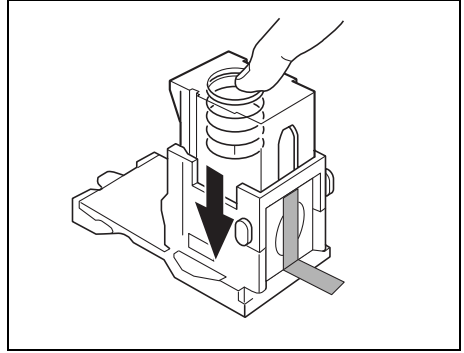

11 Peel off the tape from the staples.

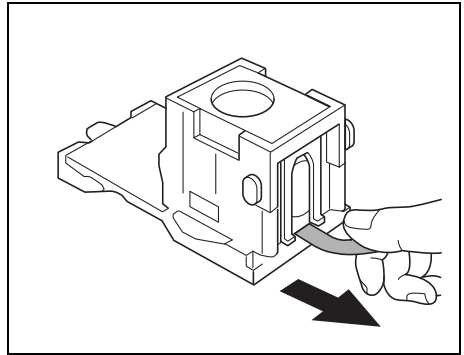

12 Insert the staple cartridge, making sure the tabs on the cartridge slide along the rails in the compartment.

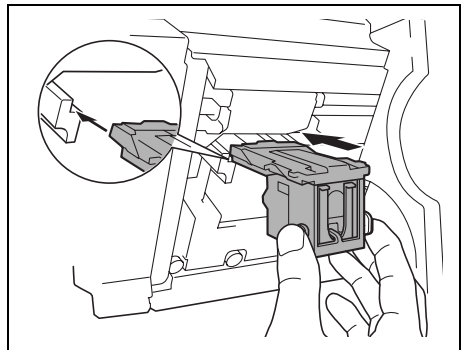

- 13 Fully insert the staple cartridge so that it locks into place.
 - Check that the staple cartridge is firmly installed.
- 14 Carefully move the stapler unit back into its original position.
- 15 Close the front door.

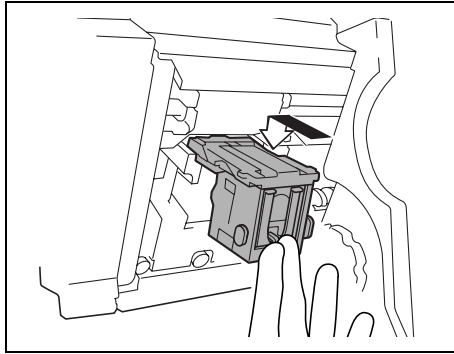

6.4 When the Message “Misfeed detected.” Appears

Locations of Paper Misfeeds

A flashing “O” indicates the location of the paper misfeed. In addition, a lit “O” indicates areas where paper may have been misfed and that should be checked. (As an example, the following illustration shows a paper jam that occurred in a paper drawer.)

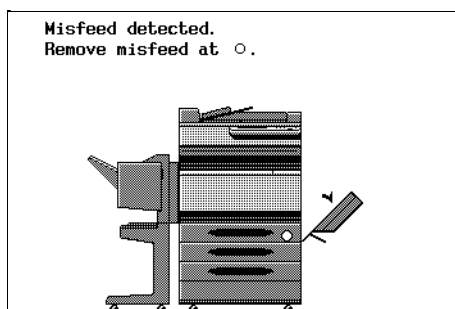

The procedure for clearing misfed paper differs depending on where the misfeed occurs. Determine the misfeed location by looking at the illustration displayed with the error message, and then clear the misfeed according to the appropriate procedure.

Locations of Paper Misfeeds in the Enlarge Display Mode

If a paper misfeed occurs while the Enlarge Display mode is being used, the message shown in the following illustration appears.

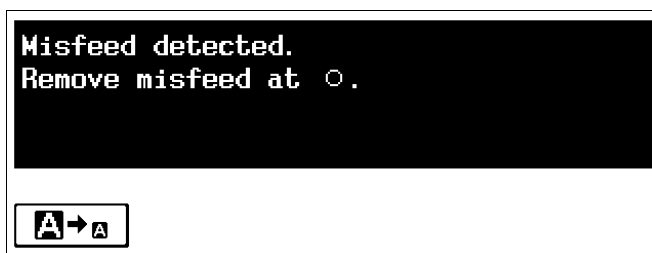

Touch **A → A** to display a screen showing where paper may have been misfed.

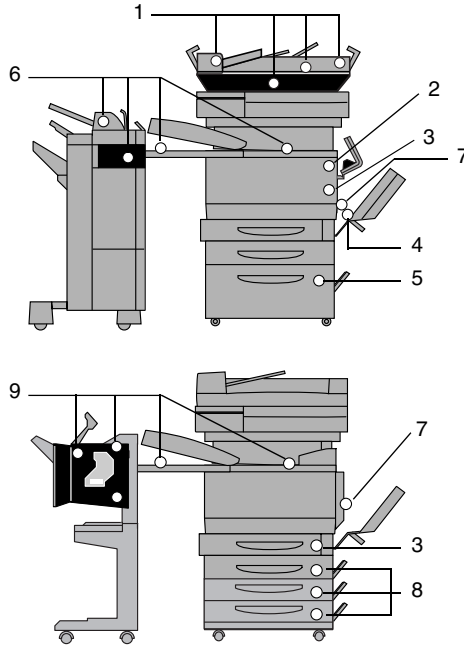

Message	Description
1	A paper misfeed in the duplexing document feeder (p. 6-31)
2	A paper misfeed in the upper right-side door unit (p. 6-28)
3	A paper misfeed in the right-side door (p. 6-25)
4	A paper misfeed in the manual bypass tray (p. 6-19)
5	A paper misfeed in the large capacity cabinet (p. 6-24)
6	A paper misfeed in finisher FN-116 (option tray) (p. 6-35)
7	A paper misfeed in the duplex unit (p. 6-21)
8	A paper misfeed in a paper drawer (p. 6-22)
9	A paper misfeed in finisher FN-8 (p. 6-39)

To clear a paper misfeed in the manual bypass tray

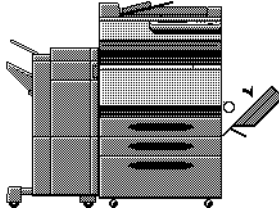

A flashing “O” indicates the location of the paper misfeed. In addition, a lit “O” indicates areas where paper may have been misfed and that should be checked.

- 1 Pull up the lock release lever to open the right-side door.

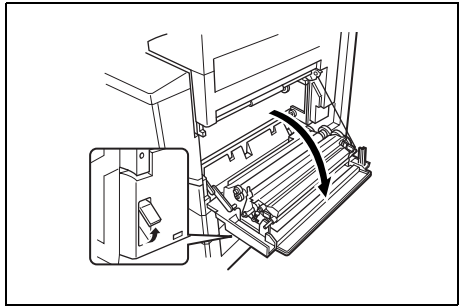

CAUTION

Decreased copy quality may result if the surface of the image transfer belt or the image transfer roller is touched.



→ Be careful not to touch the surface of the image transfer belt or the image transfer roller.

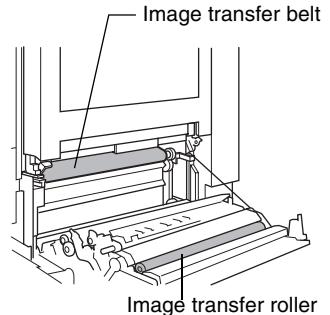

- 2 Carefully pull out the paper.
- 3 Close the right-side door.

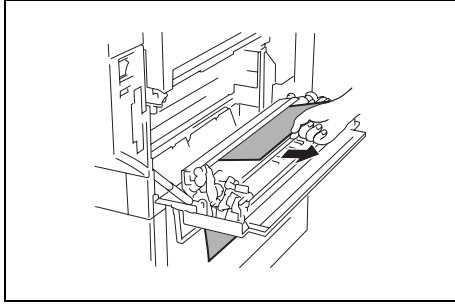

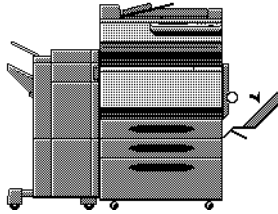
To clear a paper misfeed in the duplex unit

A flashing “O” indicates the location of the paper misfeed. In addition, a lit “O” indicates areas where paper may have been misfed and that should be checked.

- 1 Open the duplex unit door.

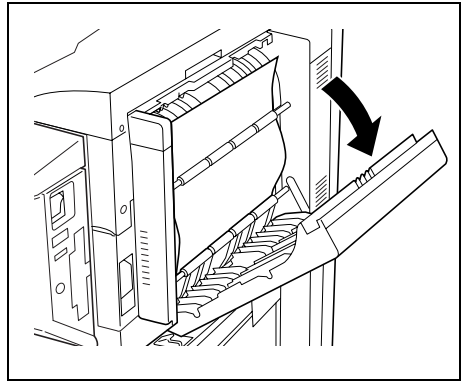

- 2 Carefully pull out the paper.
- 3 Close the duplex unit door.

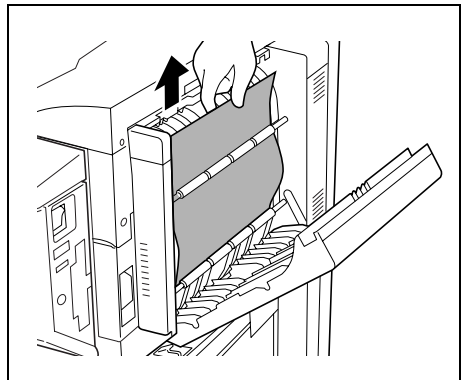

To clear a paper misfeed in a paper drawer

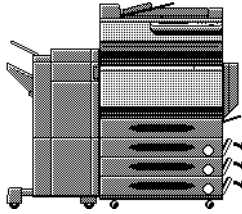

A flashing “O” indicates the location of the paper misfeed. In addition, a lit “O” indicates areas where paper may have been misfed and that should be checked.

- 1 Open the right-side door of the paper drawer indicated by the “O”.

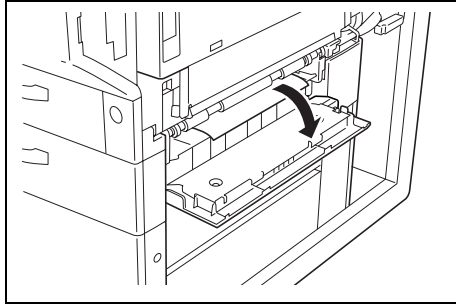

- 2 Turn the green wheels to feed the paper so that it can be easily removed.

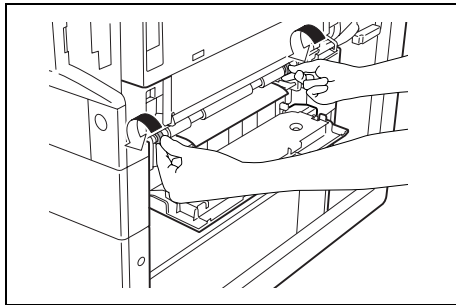

- 3 Carefully pull out the paper.
- 4 Close the lower right-side door.

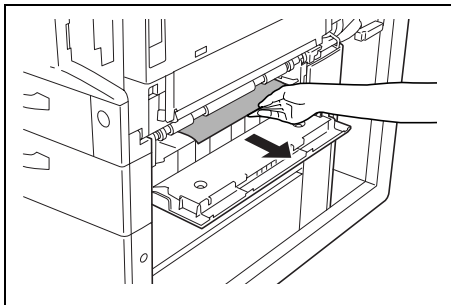

- 5 Pull out the paper drawer, and then remove any misfed paper.
- 6 Close the paper drawer.

To clear a paper misfeed in the large capacity cabinet

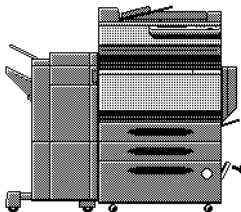

A flashing “O” indicates the location of the paper misfeed. In addition, a lit “O” indicates areas where paper may have been misfed and that should be checked.

- 1 Open the right-side door of the large capacity cabinet.

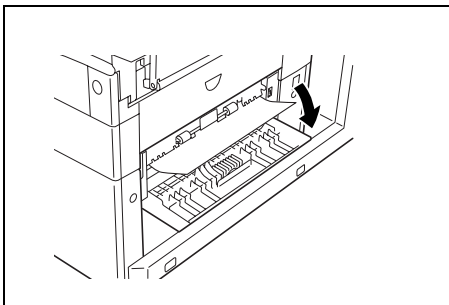

- 2 Turn the green dial in the direction of the arrow to feed out the paper.
- 3 Carefully pull out the paper.

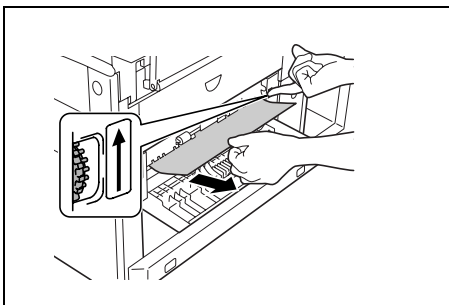

- 4 Close the right-side door of the large capacity cabinet.
- 5 Pull out the paper drawer of the large capacity cabinet, and then remove any misfed paper.
- 6 Close the paper drawer of the large capacity cabinet.

To clear a paper misfeed in the right-side door

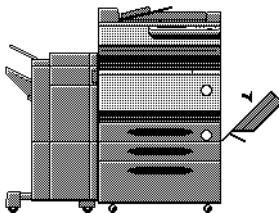

A flashing “O” indicates the location of the paper misfeed. In addition, a lit “O” indicates areas where paper may have been misfed and that should be checked.

- 1 Pull out the paper drawer being used, and then remove any paper remaining in the drawer.
- 2 Load the paper in the drawer again, and then close the drawer.



Note

Be careful not to touch the surface of the paper take-up roller with your hands.

- 3 Pull up the lock release lever to open the right-side door.

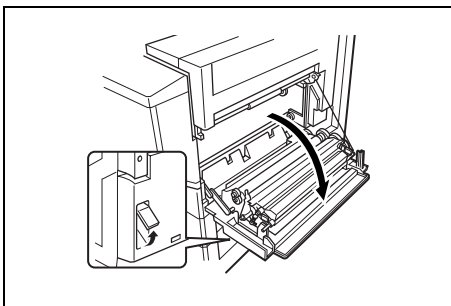
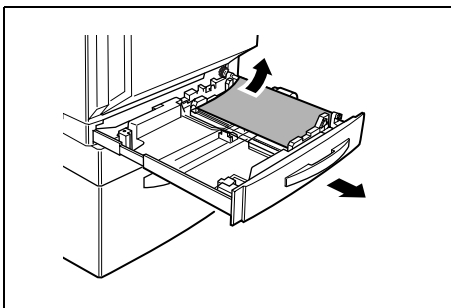

- 4 Turn the knob on the inside of the right-side door clockwise to feed out the paper.

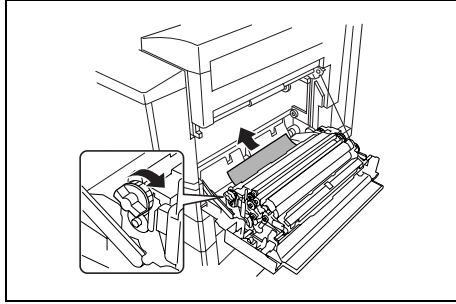

- 5 Pull out any paper caught in the image transfer roller section.

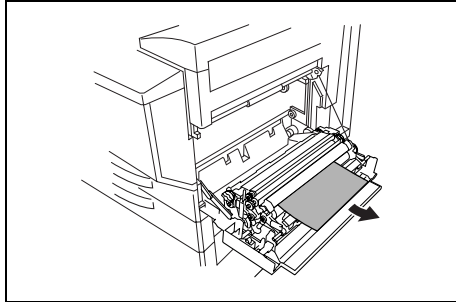

CAUTION

Decreased copy quality may result if the surface of the image transfer belt or the image transfer roller is touched.



→Be careful not to touch the surface of the image transfer belt or the image transfer roller.

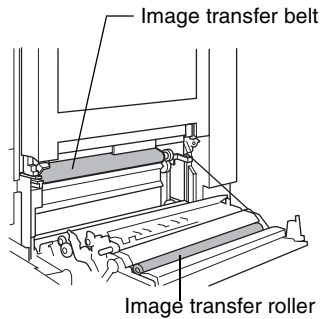

**Note**

If the paper is caught as described below, contact your technical representative.

The paper is wrapped around the roller in the image transfer roller.

The paper is folded or shredded by the roller in the image transfer roller.

The paper that was removed tore and remains in the fusing unit.

- 6 Pull out any paper caught in the fusing unit.
- 7 Open the right-side door, and then make sure that there is no paper in the fusing unit.

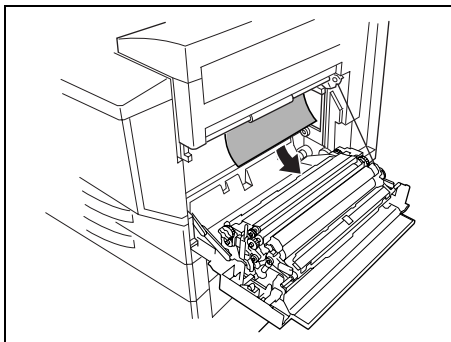

To clear a paper misfeed in the upper right-side door

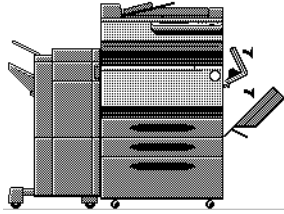

A flashing “O” indicates the location of the paper misfeed. In addition, a lit “O” indicates areas where paper may have been misfed and that should be checked.

- 1 Pull up the lock release lever to open the right-side door.

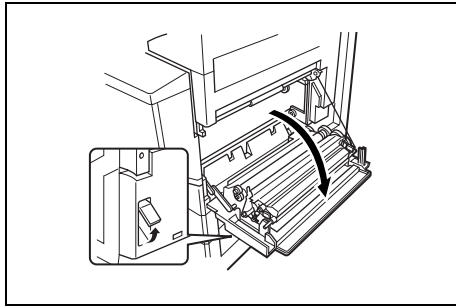

- 2 Grasp the upper right-side door as shown, and then carefully open the door completely while making sure to support it.



Note

Be sure to support the door while carefully opening it, otherwise it may be damaged.

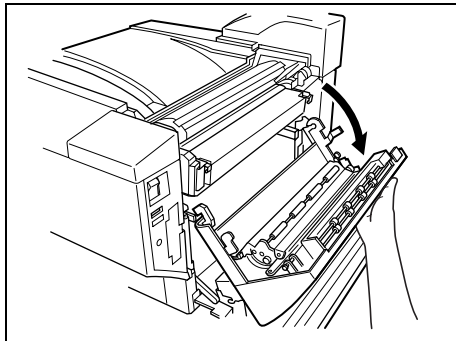

- 3 While moving the green lever on the inside of the upper right-side door in the direction of the arrow, carefully pull out the paper.

**CAUTION**

The area around the fusing unit is extremely hot.



→Touching anything other than the indicated parts may result in burns. If you get burnt, immediately cool the skin under cold water, and then seek professional medical attention.

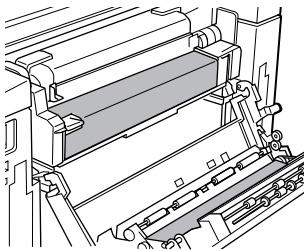

- 4 Grasp the tab on the left end of the fusing unit cover, and then swing the cover toward you to open it.

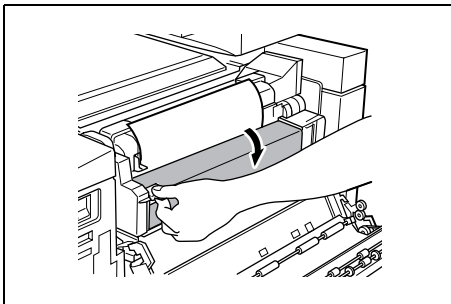

- 5 Pull out any paper caught in the fusing unit.

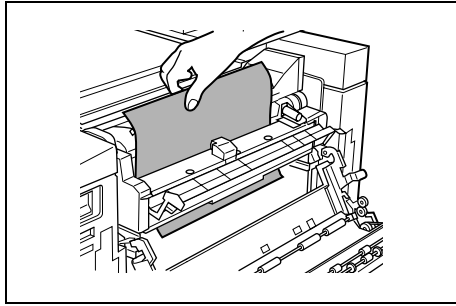

CAUTION

The area around the fusing unit is extremely hot.



→Touching anything other than the indicated levers and dials may result in burns. If you get burnt, immediately cool the skin under cold water, and then seek professional medical attention.

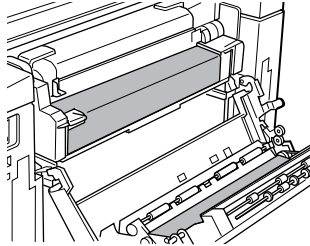

Note

If the paper is caught as described below, contact your technical representative.

The paper is wrapped around the fusing unit.

The paper is folded or shredded by the fusing unit.

The paper that was removed tore and remains in the fusing unit.

- 6 Grasp the tab on the left end of the fusing unit cover, and then return the cover to its original position.
- 7 Close the upper right-side door.
- 8 Close the right-side door.

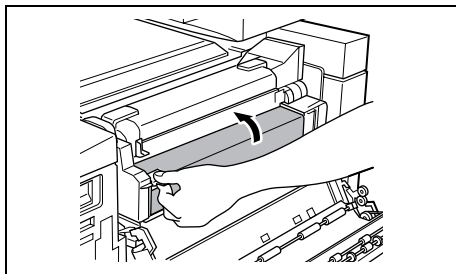

To clear a paper misfeed in the duplexing document feeder

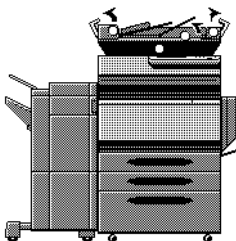

A flashing “O” indicates the location of the paper misfeed. In addition, a lit “O” indicates areas where paper may have been misfed and that should be checked.

- 1 Open the left-side misfeed-clearing cover.
- 2 Carefully pull out any documents from the document feed tray.

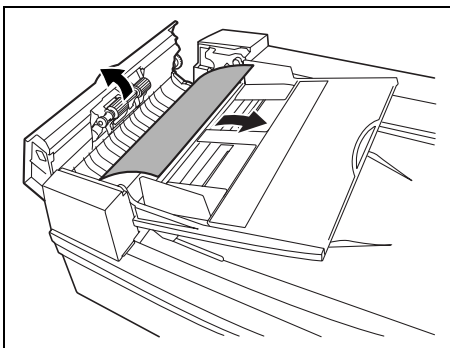

- 3 Open the right-side misfeed-clearing cover.
- 4 Turn the dial counterclockwise to feed out any documents.
- 5 Carefully pull out any documents.

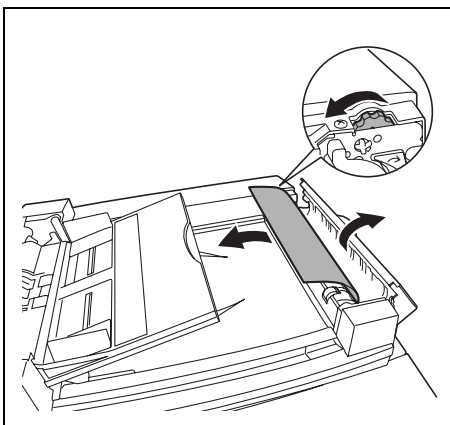

- 6 Open the guide.
- 7 Turn the dial to feed out any documents.
- 8 Carefully pull out the documents.

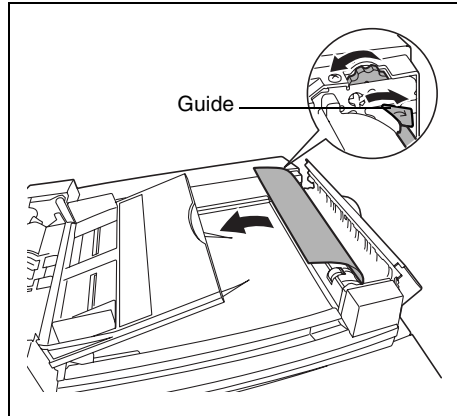

- 9 Carefully open the duplexing feed guide as far as possible.
Check that the guide remains securely open.

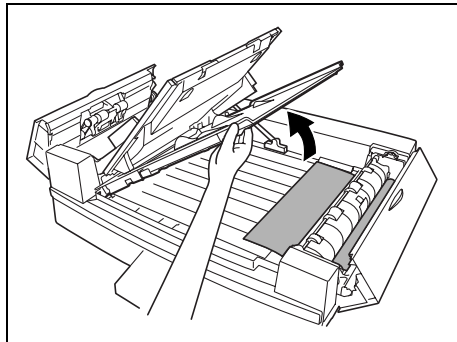

- 10 Turn the dial to feed out any documents.
- 11 Carefully pull out any documents.

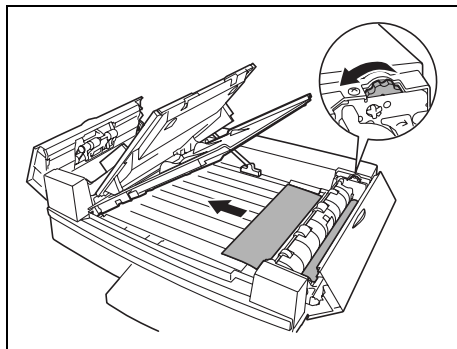

12 Close the duplexing feed guide.

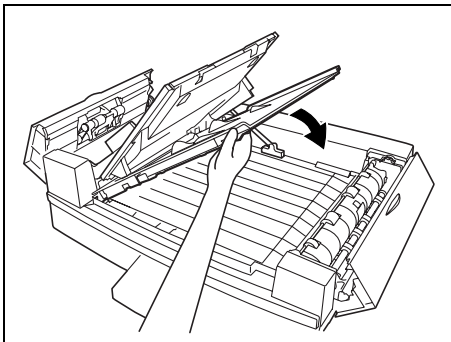

13 Open the duplexing document feeder, and then carefully pull out any documents.

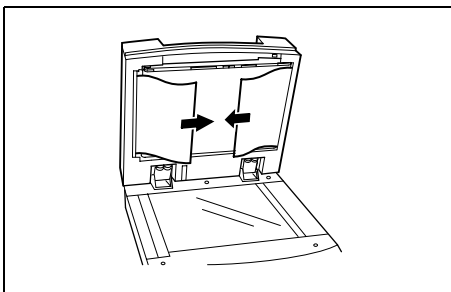

14 Remove any documents on the original glass, and then close the duplexing document feeder.

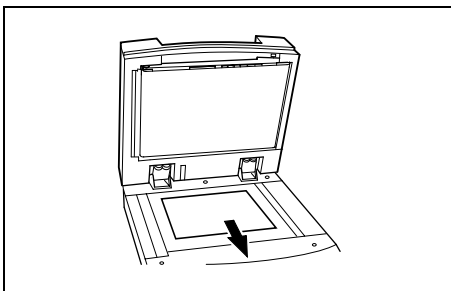

15 Close the left-side and right-side misfeed-clearing covers.

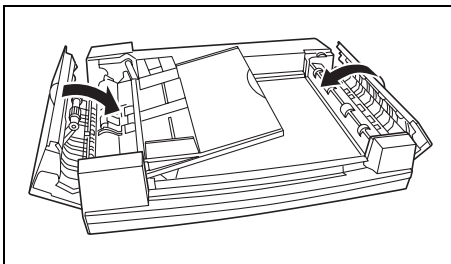

- 16** Reload the documents according to the instructions that appear on the touch panel.

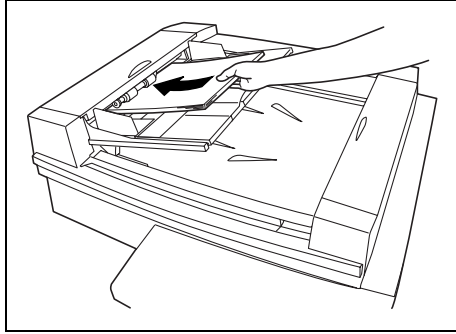

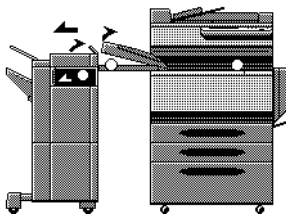
To clear a paper misfeed in finisher FN-116

A flashing “O” indicates the location of the paper misfeed. In addition, a lit “O” indicates areas where paper may have been misfed and that should be checked.

- 1 Slide the finisher away from the copier.

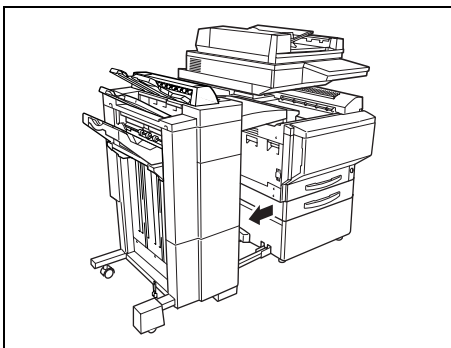

- 2 Open the horizontal transport unit cover, and then remove any paper.
- 3 Close the horizontal transport unit cover.

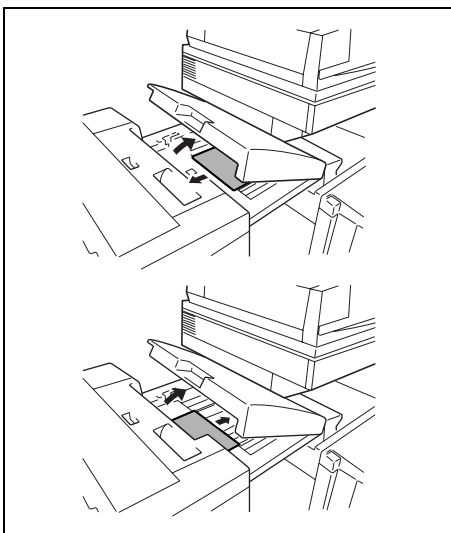

- 4 Open front door FN4.

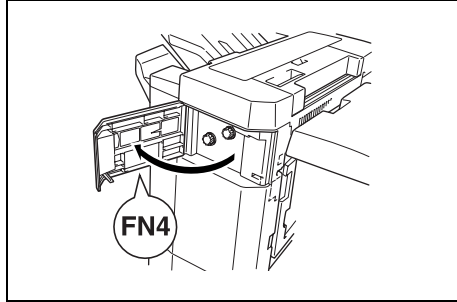

- 5 Turn knobs FN5 clockwise at the same time.

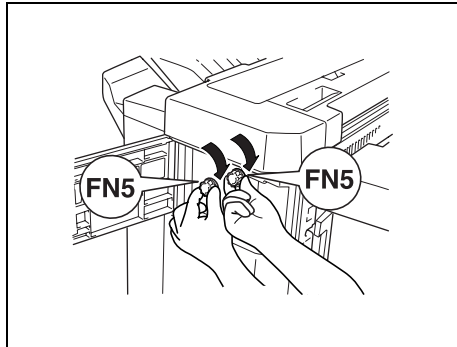

- 6 While holding the misfeed-clearing guide FN7 open, pull out any paper.

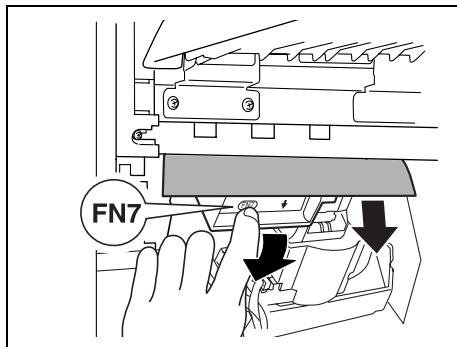

- 7 When the paper can be seen from the copy output tray, turn knobs FN5 counterclockwise at the same time to feed out any paper.

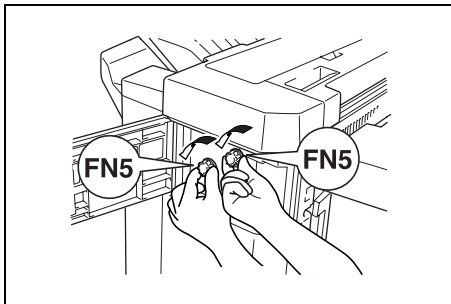

- 8 Close front door FN4.

- 9 Open upper cover FN1.

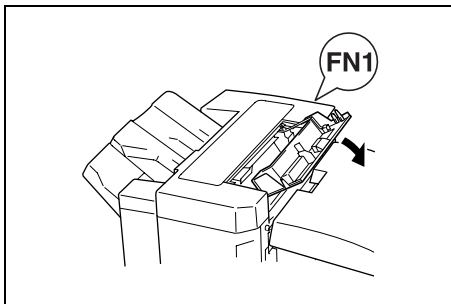

CAUTION

Metallic parts on the inside of upper cover FN1 are very hot.

- Touching anything other than the paper within the area around the fusing unit may result in burns.

- 10 While holding misfeed-clearing guide FN2 open, pull out any paper.

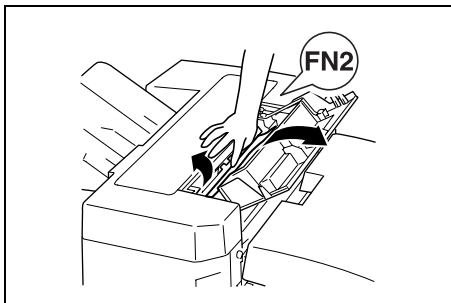

11 While holding misfeed-clearing guide FN3 open, pull out any paper.

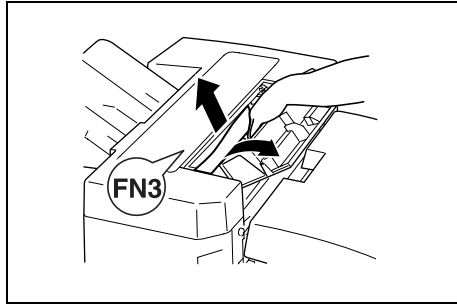

12 Close upper cover FN1.

- If the Option tray is not installed, skip to step 16.

13 If the Option tray is installed:

Open the Option tray.

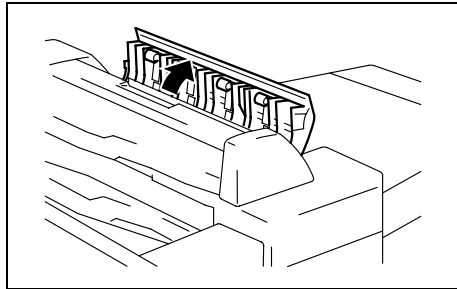

14 Remove any misfed paper.

15 Close the Option tray.

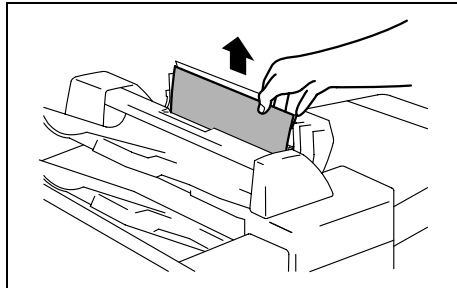

16 While holding misfeed-clearing guide FN6 open, pull out any paper.

17 Slide the finisher back against the copier.

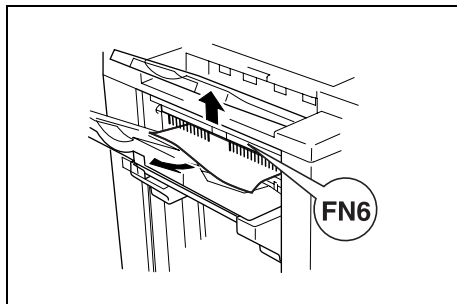

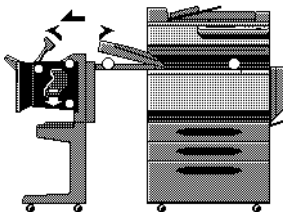
To clear a paper misfeed in finisher FN-8

A flashing “O” indicates the location of the paper misfeed. In addition, a lit “O” indicates areas where paper may have been misfed and that should be checked.

- 1 Slide the finisher away from the copier.

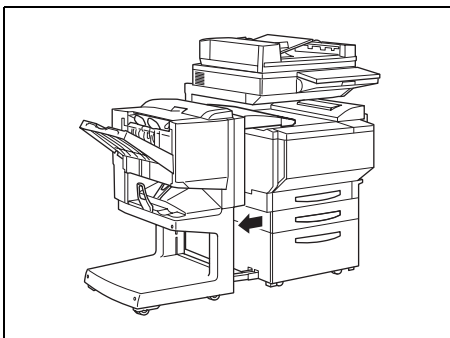

- 2 Open the cover of the horizontal transport unit.
- 3 Remove any paper, and then close the cover of the horizontal transport unit.

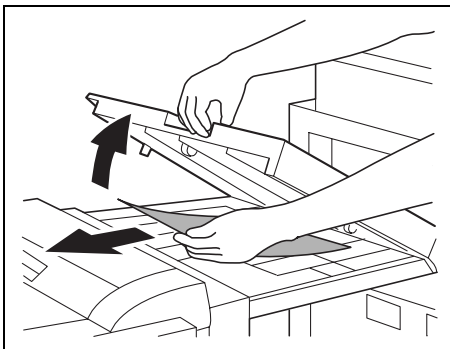

- 4 Open the front door of the finisher.

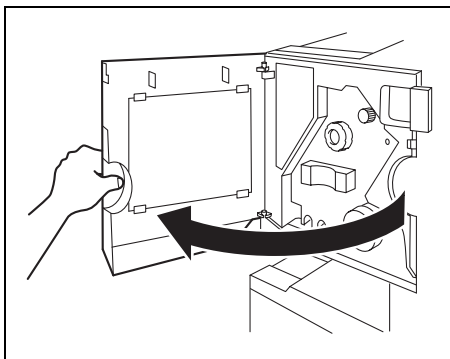

- 5 Turn misfeed-clearing dial ① clockwise until the removal indicator is completely blue.
- If the dial is turned too far, turn it counterclockwise to adjust it.



Note

If the message “Misfeed detected” appears, be sure to perform these steps. If the paper is pulled out with too much force without performing these steps, the finisher may be damaged.

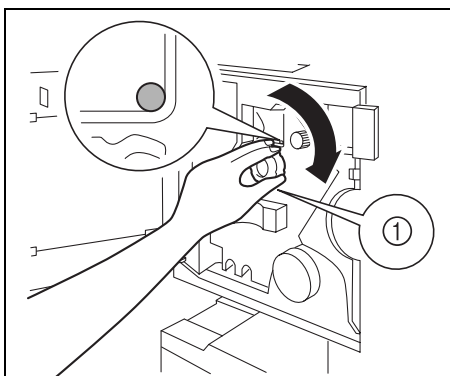

- 6 Open the upper door of the finisher, and then pull out any paper in the feed section.

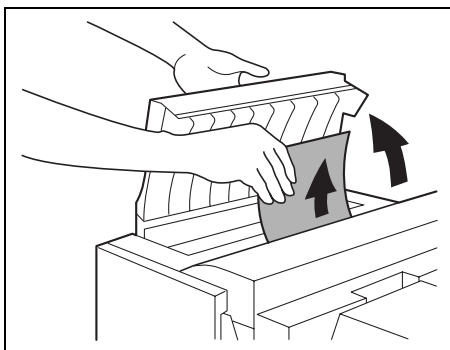

- 7 Close the upper door.

- 8 Pull out any paper fed into the output tray.

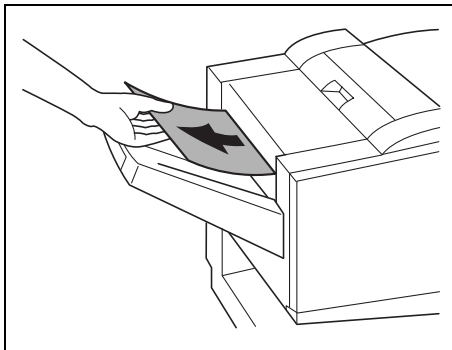

- 9 Open the feed guide for the finisher, and then remove any paper.

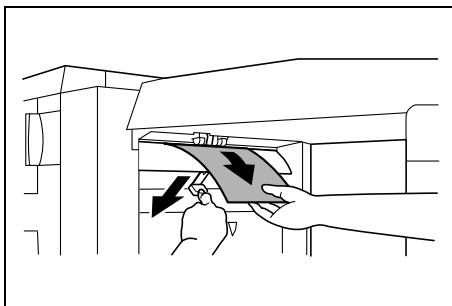

- 10 Open the transport guide, and then pull out any paper in the transport section.



Note

If the paper cannot easily be pulled out, stop trying to pull it out.

Pulling out the paper with too much force may damage the folding unit.

If the paper cannot be pulled out easily, turn the misfeed-clearing dial in the folding section as described in the following step, and then pull out the paper.

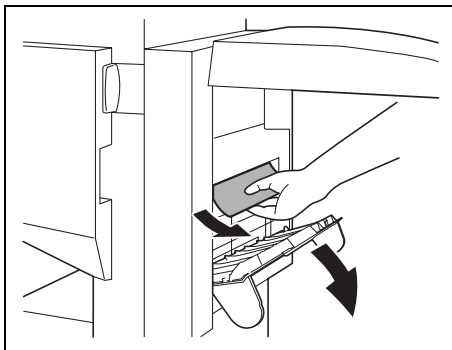

- 11** If the paper could not be removed in step 10, turn the misfeed-clearing dial in the folding section clockwise.

Feed the paper into the lower paper output tray, and then pull it out.

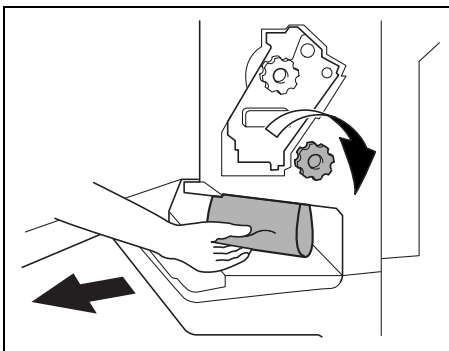

- 12** Close the front door of the finisher.



Note

Be careful that your fingers are not pinched when the front door is closed.

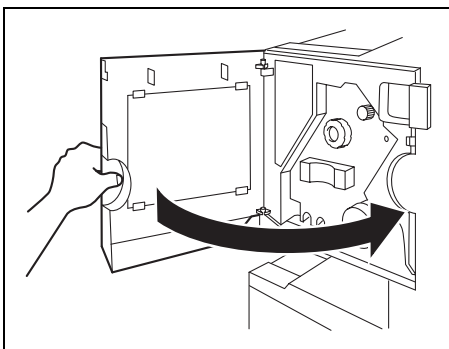

- 13** Slide the finisher back against the copier.

6.5 When the Message “Staple mode cannot be used.” Appears

To clear jammed staples in FN-116

When a finisher is installed and the staples are jammed, the message shown below appears.

Follow the procedure below to clear the jammed staples.

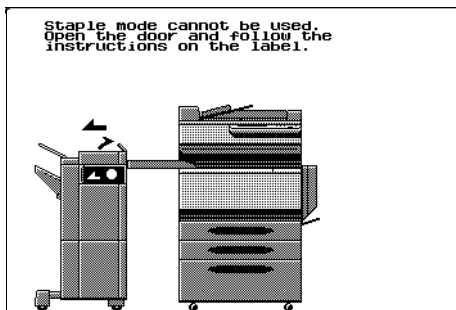

- 1 Slide the finisher away from the copier.

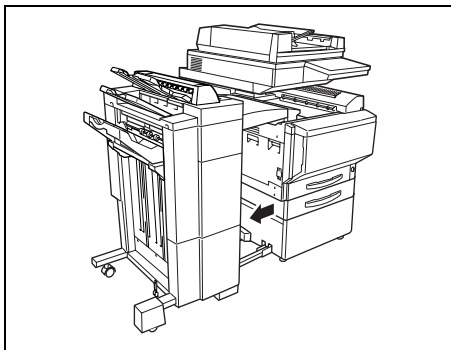

- 2 Turn the dial to the left in order to position the stapler at the center.

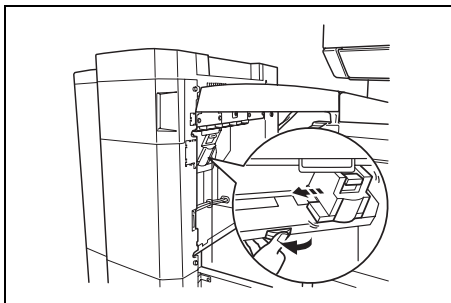

- 3 Pull the stapler holder out toward you.

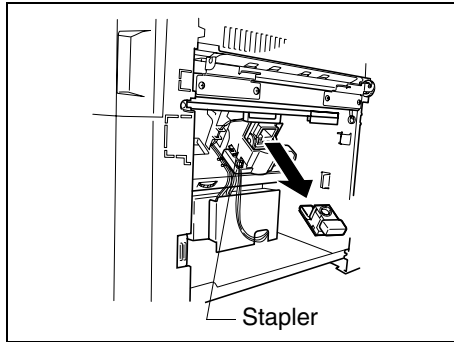

- 4 Push the staple holder guide up, and then pull out one sheet of staples.

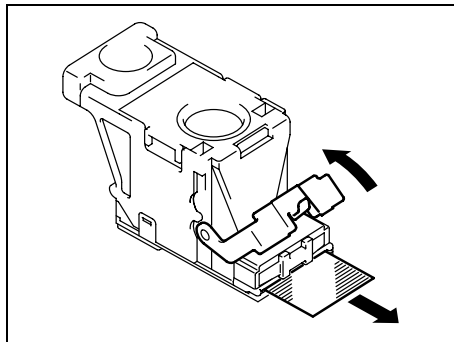

- 5 Move the guide back to its original position.

- 6 Insert the stapler holder until it locks into place.

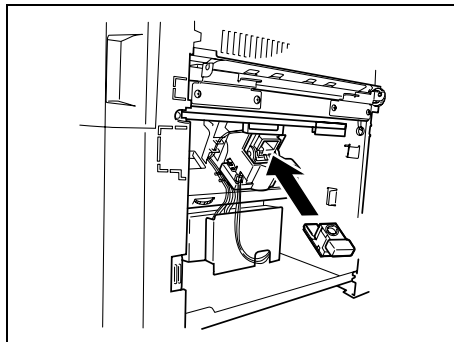

- 7 Slide the finisher back against the copier.



Note

If stapling still cannot be performed, even after performing the above procedure, contact your technical representative.

To clear jammed staples in FN-8

When a finisher is installed and the staples are jammed, the message shown below appears.

Follow the procedure below to clear the jammed staples.

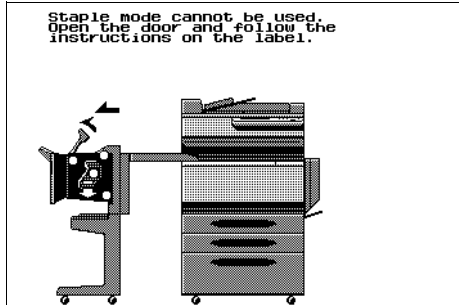
**Note**

If the message “Staple mode cannot be used.” appears, be sure to perform the following procedure.

If the paper is pulled out in any way other than that described below, the stapler unit may be damaged.

- 1 Slide the finisher away from the copier.

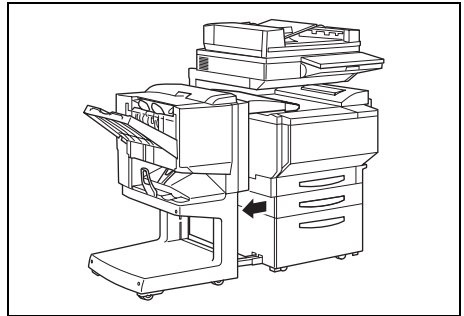

- 2 Open the cover of the horizontal transport unit.
- 3 Remove any paper, and then close the cover of the horizontal transport unit.

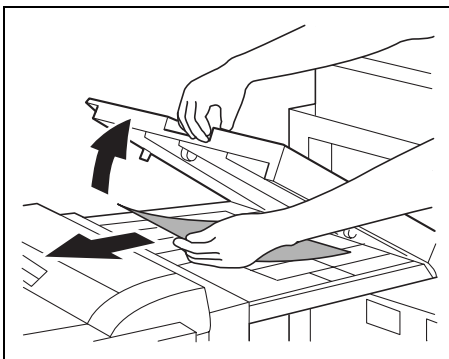

- 4 Open the feed guide for the finisher, and then remove any paper.

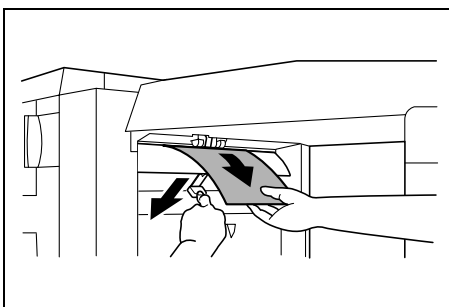

- 5 Open the front door of the finisher.

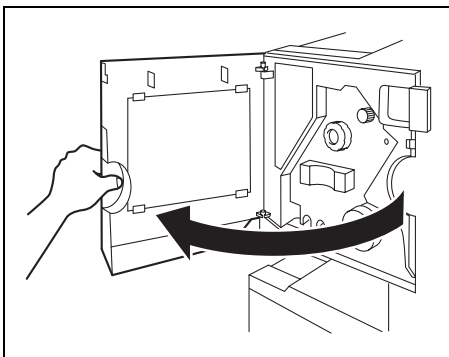

- 6 Turn misfeed-clearing dial ① clockwise until the removal indicator is completely blue.
- If the dial is turned too far, turn it counterclockwise to adjust it.



Note

If the message “Staple mode cannot be used.” appears, be sure to perform these steps. If the paper is pulled out with too much force without performing these steps, the finisher may be damaged.

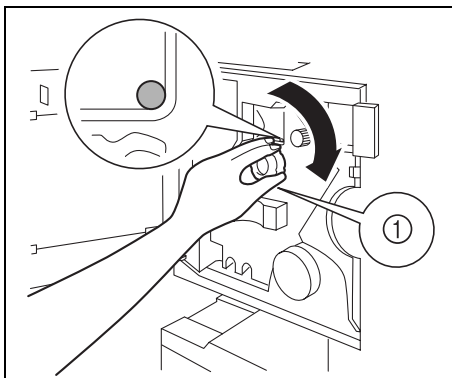

- 7 Pull out any paper fed into the output tray.

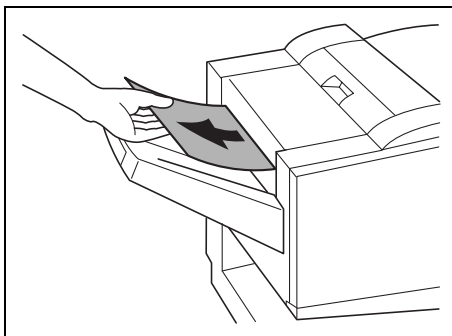

- 8 Open the transport guide, and then pull out any paper in the transport section.



Note

If the paper cannot easily be pulled out, stop trying to pull it out. Pulling out the paper with too much force may damage the folding unit.

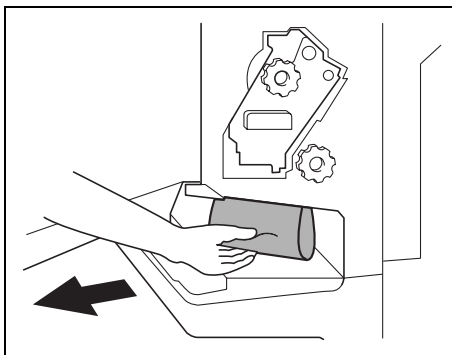

If the paper cannot be pulled out easily, turn the misfeed-clearing dial in the folding section as described in the following step, and then pull out the paper.

- 9 Turn the misfeed-clearing dial in the folding section clockwise. Feed out into the lower output tray the paper that could not be fed out in step 8, and then pull out the paper.

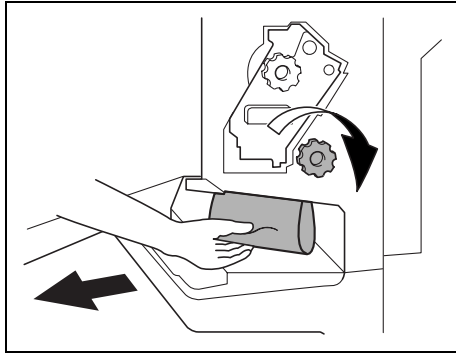

- 10 Slowly pull out the stapler unit as far as possible.

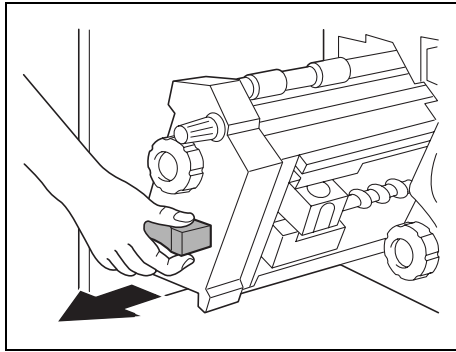

- 11 Turn misfeed-clearing dial ② clockwise until the cartridge removal indicators are aligned. The staple cartridge moves to a position from where it can be removed.

- If the dial is turned too far, turn it counterclockwise to adjust it so the cartridge removal indicators are aligned.

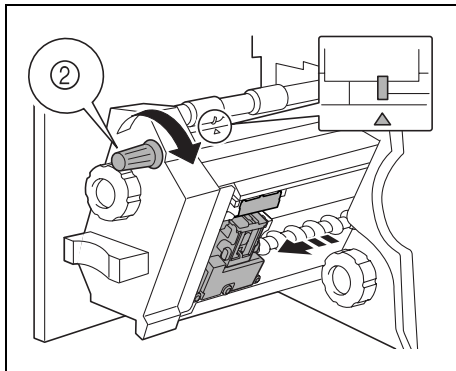

- 12 Grasp both sides of the staple cartridge, lift up the staple cartridge, and then pull it out.

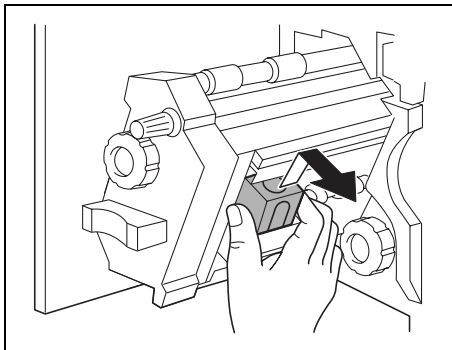

- 13 Swing open the shutter of the staple cartridge.

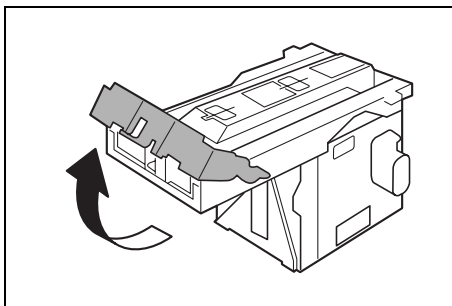

- 14 Pull out toward you the two staples jammed at the end of the staple cartridge.



Note

Be sure to remove two staples, otherwise stapling cannot continue correctly.

- 15 Return the shutter of the staple cartridge to its original position.

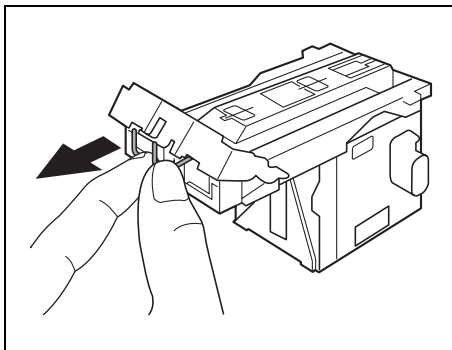

- 16** Insert the staple cartridge, making sure the tabs on the cartridge slide along the rails in the compartment.

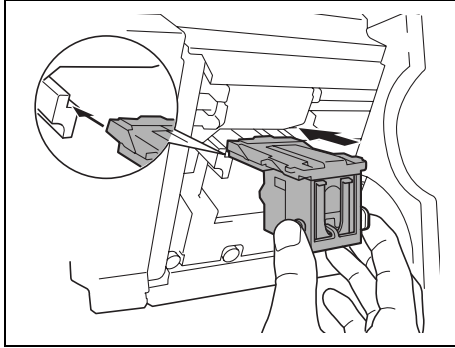

- 17** Fully insert the staple cartridge so that it locks into place.

- Check that the staple cartridge is firmly installed.

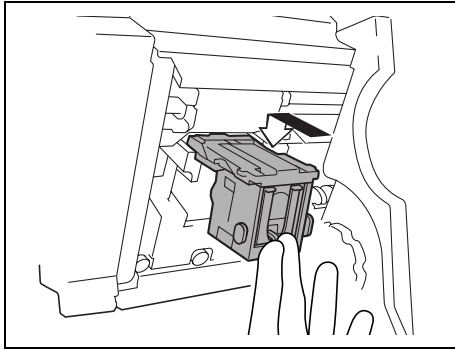

- 18** Carefully move the stapler unit back into its original position.

- 19** Close the front door.

- 20** Slide the finisher back against the copier.

6.6 When the Message “Remove Punch scraps.” Appears

If the punch kit is installed in the finisher FN-8, the following message will appear when the hole-punch waste container is full.



Display in Enlarge Display Mode

If the hole-punch waste container is full,  appears in the screen on the touch panel.

Touch  to display a message (if it can be emptied by the user).



To empty the hole-punch waste container

Empty the hole-punch waste container, and then re-install it according to the following procedure.

- 1 Slide the finisher away from the copier.

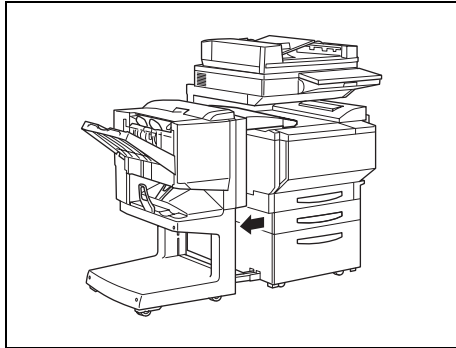

- 2 Pull out the hole-punch waste container.

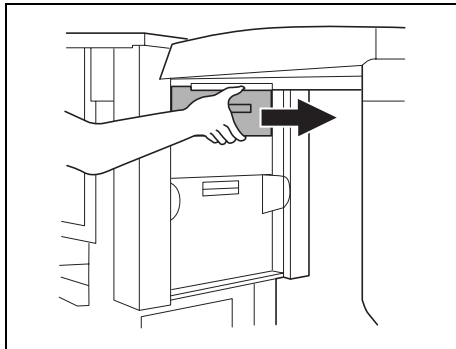

- 3 Empty the container.
- 4 Insert the hole-punch waste container into its original position.
- 5 Slide the finisher back against the copier.

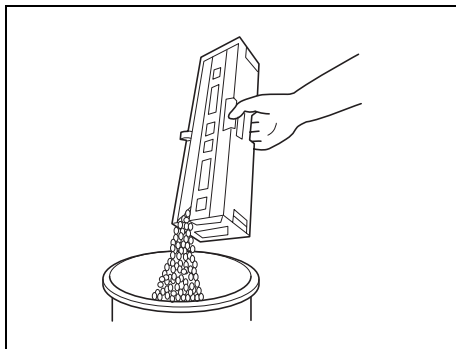



6.7 When the Inspection Mark “” Appears

When the inspection mark () in the lower-left corner of the Basic screen appears, the image stabilization or printing or scanning functions of the copier have become unstable.



Display in Enlarge Display Mode

If an error occurs during image stabilizing, printing or scanning,  appears in the screen on the touch panel. Touch  to display the message shown in the following illustration.



Contact your technical representative.

**Note**

Touching the inspection mark () that appears in the Basic screen displays a screen like that shown below. When contacting the technical representative, inform them of the numbers (“P-7” for the example below) listed in the screen that appears. Touching [Exit] in the top-right corner displays the Basic screen again.

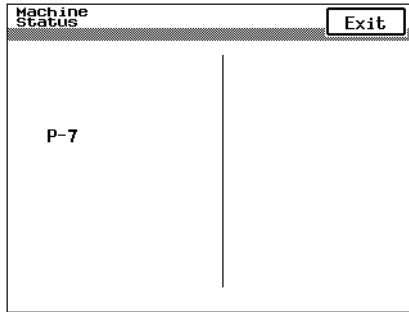
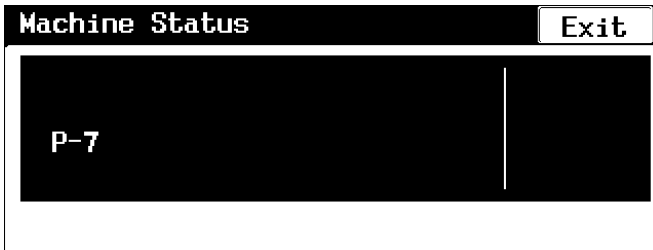
**Display in Enlarge Display Mode**

6.8 When the Message “Malfunction detected.” Appears

When the message shown below appears in the touch panel, a malfunction has occurred within this copier.

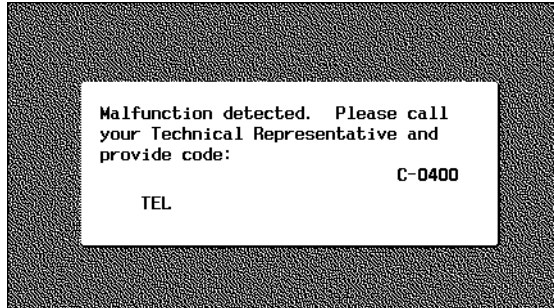

Display in Enlarge Display Mode

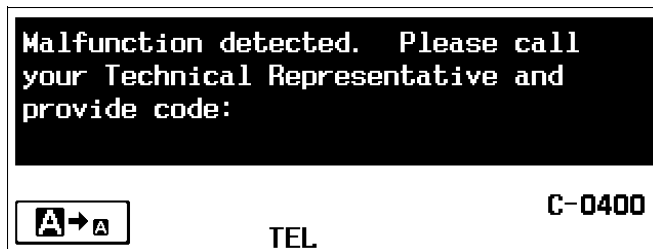

Contact your technical representative.



Note



When contacting the technical representative, inform them of the code (“C-0400” for the example above) in the screen that appears.

6.9 When the Message “XXXX needs to be replaced soon.” Appears

When it is almost time to replace supplies or a part within this copier, the message shown in the following illustration appears, warning about the replacement period. (As an example, the message warning that the yellow imaging unit will soon need to be replaced is shown below.)



Display in Enlarge Display Mode

If the replacement period is almost reached,  appears in the screen on the touch panel. Touch  to display the message shown in the following illustration.

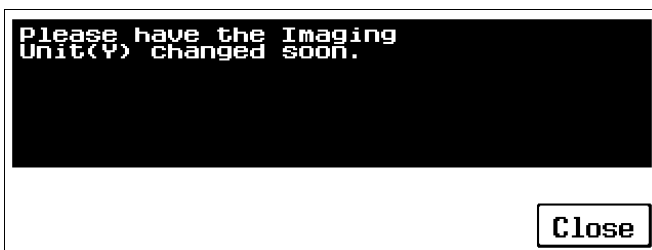

When the message appears, prepare to replace the specified supplies or part according to your maintenance agreement.

After the message warning that the part/supplies should soon be replaced, the message indicating that the part/supplies should be replaced appears and the copier stops operating.

The number of copies that can be made from the time that the message appears warning that the part/supplies should soon be replaced until the time that the message appears indicating that the part/supplies should be replaced differs depending on the specified copy settings and the part/supplies.

6.10 When the Message “Replace XXXX.” Appears

When it is time to replace supplies or a part within this copier, a message appears, indicating that the part or supplies should be replaced, and the copier stops operating.

As an example, the message indicating that the yellow imaging unit should be replaced (if replaceable by the user) is shown below.

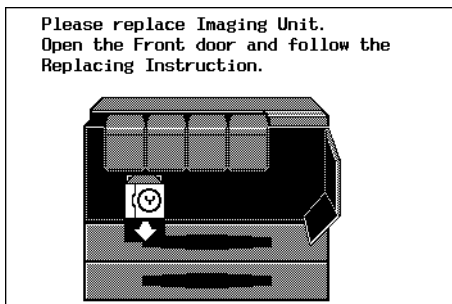

Display in Enlarge Display Mode

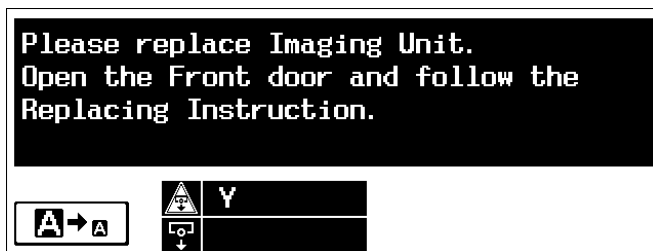

When the message appears, replace the specified supplies or part according to your maintenance agreement.



CAUTION

Used supplies or part

- In order to prevent the used supplies or part from dirtying anything, keep it in the box.
- Dispose of the used supplies or part according to your local regulations.

6.11 Other Messages

Message	Cause	Remedy
Original left on the Glass.	The document was left on the original glass.	Remove the document from the original glass.
Matching paper size is not available. Reselect the paper size.	Paper of a suitable size is not loaded in a paper drawer.	Either select a different copy size or manually feed paper of a suitable size.
Original's size cannot be detected. Reselect the paper size.	(1) The document is not positioned correctly. (2) A document with an unspecified size or with a size too small to be detected is loaded.	(1) Position the document correctly. (2) Select the correct paper size.
This mode cannot be selected with the XXXXXX.	Functions that cannot be used together are selected.	Make copies using only one of the functions.
The Exit Tray has reached its capacity.	Since the maximum amount of copies for the indicated finisher output tray has been exceeded, the copier is unable to make copies.	Remove all copies from the indicated tray.
Please input your 4-digit Access# and press the Access key.	Access codes have been specified. Copies cannot be made unless a specified access code is entered.	Enter your access code. (See section 2.6 of the Basic Operations volume.)
Your account has reached its maximum allowance.	The limit on the number of copies that can be made has been reached.	Contact your technical representative.
Section -> is open. Close it properly.	Since a copier door or cover is open or an option is not installed correctly, the copier is unable to make copies.	Make sure that all doors and covers are closed and that all options are installed correctly.
Please insert the Fusing Unit and close all doors.	The fusing unit is not installed correctly.	Reinstall the supplies or parts, or contact your technical representative.
Install the CF toner cartridge, and then move the lever to the correct position.	The indicated toner cartridge is not installed correctly.	
Please insert the Waste Toner Bottle and close all doors.	The waste-toner bottle is not installed correctly.	
Please insert the Image Transfer Belt Unit and close all doors.	The image transfer belt unit is not installed correctly.	
Replenish paper.	The indicated drawer has ran out of paper.	Load paper into the indicated drawer. (See section 3.5 of the Basic Operations volume.)
CF Toner cartridge (X) needs to be replaced soon.	The toner for the indicated color is about to run out.	Replace the toner cartridge according to your maintenance agreement.
Toner X is empty.	Since the toner for the indicated color has run out, the copier is unable to make copies.	



Message	Cause	Remedy
Replace Staple Cartridge X.	The staples have run out.	Replace the staple cartridge. (p. 6-9)
Misfeed detected.	Since a paper misfeed occurred, the copier is unable to make copies.	Clear the paper misfeed. (p. 6-17)
Re-insert the following# of originals:	After clearing a paper misfeed, it is necessary to reload the documents that have already been fed through the document feeder.	Load the indicated document pages into the document feeder.
Malfunction detected. Call your Technical Rep. and provide code:	The copier malfunctioned and is unable to make copies.	Inform your technical representative of the code displayed on the touch panel.

If any message other than those listed above appears, perform the operation described in the message.

Troubleshooting

7

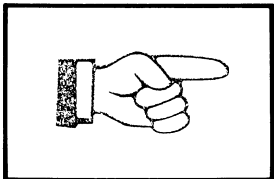
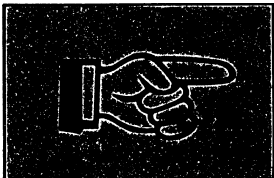
7.1 When the Print Quality Is Low

Symptom	Possible Cause	Remedy
The printed output is too light. 	The copy density is set too light.	Select a darker setting for the "Density" parameter. (See section 1.2 in the Basic Operations volume.)
	The paper is damp.	Replace the paper. (See section 3.5 in the Basic Operations volume.)
The printed output is too dark. 	The copy density is set too dark.	Select a lighter setting for the "Density" parameter. (See section 1.2 in the Basic Operations volume.)
	The document is not pressed tight enough against the original glass.	Position the document so that it is pressed tightly against the original glass. (See section 4.2 in the Basic Operations volume.)
The printed output is blurry. 	The paper is damp.	Replace the paper. (See section 3.5 in the Basic Operations volume.)
	The document is not pressed tight enough against the original glass.	Position the document so that it is pressed tightly against the original glass. (See section 4.2 in the Basic Operations volume.)

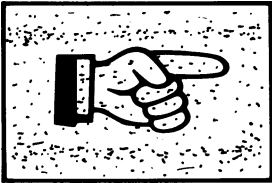
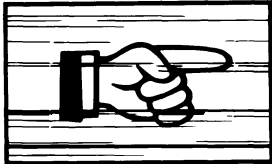
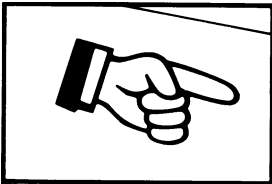
Symptom	Possible Cause	Remedy
<p>There are dark specks or spots throughout the printed output.</p> 	The original glass is dirty.	Wipe the glass with a soft dry cloth. (See p. 8-8)
	The document pad is dirty.	Clean the document pad with a soft cloth dampened with a mild detergent. (See p. 8-9)
	The original is very thin or highly translucent.	Place a blank sheet of paper over the document. (See section 1.7 in the Advanced Operations volume.)
	A double-sided document is being copied.	If a thin double-sided document is being copied, the information on the back side may be reproduced in the copy. Select a lighter setting for the "Background" parameter. (See section 5.8 in the Basic Operations volume.)
<p>White or black lines on the printout.</p> 	The electrostatic charger is dirty.	Use the charger-cleaning tool to clean the electrostatic charger. (See p. 8-10)
	The image is not aligned properly on the paper.	<p>The document is not positioned correctly.</p> <p>Correctly position the document against the document width scale. (See section 4.2 in the Basic Operations volume.)</p> <p>Correctly load the document into the duplexing document feeder, and then slide the document guides against it. (See section 4.2 in the Basic Operations volume.)</p>
	The document is not positioned correctly in the duplexing document feeder.	Open the duplexing document feeder, and correctly position the document against the document width scale. (See section 4.2 in the Basic Operations volume.)
	The original glass is dirty (while using the duplexing document feeder).	Wipe the glass with a soft dry cloth. (See p. 8-8)
	The document guides are not positioned along the edges of the paper.	Slide the document guides against the edges of the paper.
	Curled paper was loaded into the paper drawer.	Flatten the paper before loading it.
	<p>The printed page is curled.</p>	<p>The paper that was used (recycled paper) was curled.</p>
Replace the paper with paper that is not damp.		

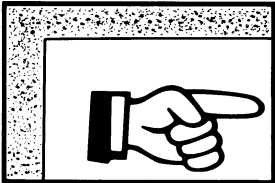
Symptom	Possible Cause	Remedy
<p>The edge of the printed output is dirty.</p> 	The document pad is dirty.	Clean the document pad with a soft cloth dampened with a mild detergent. (See p. 8-9)
	The selected paper size is larger than the document (with Zoom set to "× 1.000").	Select a paper size that is the same size as the document. (See section 2.2 in the Basic Operations volume.) Otherwise, set Zoom to "Auto Size" to enlarge the copy to the selected paper size. (See section 5.3 in the Basic Operations volume.)
	The orientation of the document is different from the orientation of the paper (with Zoom set to "× 1.000").	Select a paper size that is the same size as the document. Otherwise, select a paper orientation that is the same as that of the document.
	The copy was reduced to a size smaller than the paper (a CustomZoom setting was selected).	Select a zoom ratio that adjusts the document size to the selected paper size. (See section 5.3 in the Basic Operations volume.) Otherwise, set Zoom to "Auto Size" to reduce the copy to the selected paper size. (See section 5.3 in the Basic Operations volume.)

7.2 When the Copier Is Not Operating Correctly

Symptom	Possible Cause	Remedy
Nothing appears on the touch panel.	If only the indicator on the [Start] key is lit, the copier is in Energy Saver mode.	Press any key to cancel Energy Saver mode. (See section 1.5 in the Basic Operations volume.)
	The contrast control knob for the touch panel has been set either too light or too dark.	While looking at the touch panel, adjust the contrast control knob. (See section 1.6 in the Basic Operations volume.)
	The scanner power cord or the interface cable are disconnected.	Set the power switch for the copier to "O", and then re-connect the scanner power cord and the interface cable.
The indicator on the [Start] key does not light up in green.	An access code has not been entered.	Enter your access code. (See section 2.6 of the Basic Operations volume.)
Even though the [Start] key is pressed, no copies are made	The copy/print job is queued for printing.	Touch [Job Log] to check the jobs that are queued. Wait until printing begins.
	The copier is still warming up after just being turned on.	The copier takes about 5 minutes to warm up after it is turned on. Wait until the copier has finished warming up.
	The copier is malfunctioning	Follow any messages that appear on the touch panel.
Keys on the control panel do not respond.	If the indicator on the [Interrupt] key is lit, the copier is in Interrupt mode. Interrupt 	Press the Interrupt key to cancel the mode. (See section 2.4 in the Basic Operations volume.)
The copier cannot be turned on.	The power supply cord may have been unplugged from the electrical outlet.	Plug the power supply cord into an electrical outlet.
	The room's circuit breaker was tripped.	Close the room's circuit breaker.

Appendix

8

8.1 Specifications

Copier CF2002/CF3102

Specification	
Type	Desktop
Platen	Stationary
Photo conductor	OPC
Copying system	Dry-type electrophotographic method
Developing system	MTHG developing method
Fusing system	Belt-fixing
Resolution	Scanning: 600 dpi, Printing: 600 dpi × 1800 dpi equivalent
Document	Types: Sheets, books, and other three-dimensional objects Size: Maximum Ledger (11 × 17), Weight: 4.4 lbs.
Paper types	Plain paper (17 to 24 lbs.), thick paper 1* (24-1/4 to 40 lbs.), thick paper 2* (40-1/4 to 55-1/2 lbs.), thick paper 3* (55-3/4 to 68 lbs.), overhead projector transparencies*, postcards*, envelopes*, label sheets* * Can only be fed through the 1st drawer or the manual bypass tray.
Paper sizes	1st drawer: 12-1/4 × 18 L* to 5-1/2 × 8-1/2 L, 4 × 6 thick paper* (Width: 3-9/16 to 12-1/4 in., Length: 5-1/2 to 18 in.) 2nd drawer: 11 × 14 L, Ledger L (11 × 17 L), Legal L (8-1/2 × 14 L), Letter L/C (8-1/2 × 11 L/C), 8 × 13 L, 8-1/4 × 13 L, 8-1/2 × 13 L, 8-3/4 × 13 L, 10-1/2 × 8 C Manual bypass tray: (Width: 3-9/16 to 12-1/4 in., Length: 5-1/2 to 18 in.) * Can only be fed through the 1st drawer or the manual bypass tray.
Paper capacity	1st drawer: 250 sheets (when using 17 lbs. plain paper) 2nd drawer: 500 sheets (when using 17 lbs. plain paper) Manual bypass tray: 1 sheet (plain paper, thick paper 1, thick paper 2, thick paper 3, overhead projector transparency, or postcard)
Warm-up time	Less than 5 minutes at room temperature (68°F)
Lost image	Leading edge: 1/4 in. (5 mm) Trailing edge: 1/8 in. (3 mm) Rear edge: 1/8 in. (3 mm) Font edge: 1/8 in. (3 mm)
First copy (CF2002)	Full color: Less than 14.1 seconds Black: Less than 7.9 seconds (for Letter C paper loaded into the 1st drawer)
First copy (CF3102)	Full color: Less than 9.9 seconds Black: Less than 7.9 seconds (for Letter C paper loaded into the 1st drawer)
Copy speed (CF2002)	Full color/Black: For Letter C paper loaded into the 2nd drawer: 20/31 sheets/min. For Ledger L paper loaded into the 2nd drawer: 10/15 sheets/min.

Specification	
Copy speed (CF3102)	Full color/Black: For Letter C paper loaded into the 2nd drawer: 31/31 sheets/min. For Ledger L paper loaded into the 2nd drawer: 15/15 sheets/min.
Magnification ratios	Full size: $\times 1.000$ Enlargement ratios: $\times 1.214$, $\times 1.294$, $\times 1.545$ and $\times 2.000$ Reduction ratios: $\times 0.785$, $\times 0.733$, $\times 0.647$, $\times 0.500$, minimal ($\times 0.930$) Zoom ratios: $\times 0.250$ to $\times 4.000$ (in $\times 0.001$ increments), and 3 memory zoom ratios
Multiple copies	1 to 999 sheets
Density control	Automatic and manual
Power requirements	110/120/127 V: 15 A 60 Hz 220-240 V: 10 A 50/60 Hz
Power consumption	Less than 1.5 kW
Dimensions	Scanner: 23-1/4 in. (width) \times 28-3/4 in. (depth) \times 6 in. (height) Printer: 23-1/2 in. (width) \times 28-3/4 in. (depth) \times 22-1/2 in. (height)
Space requirements	25-1/4 in. (width) \times 31-1/4 in. (depth) (with the copier stand installed)
Memory	M256-2 (US, Canada: Standard, Others: Optional)
Weight	Scanner: 43 lbs. Printer: 187-1/4 lbs. (with all four imaging units installed)

Duplex Unit AD-14

Specification	
Paper type	Plain paper 17 to 24 lbs.
Paper size	12-1/4 \times 18, 11 \times 14 L, 8-1/2 \times 14 L, 8-1/2 \times 13 L, 8-1/2 \times 11 L/C, 8 \times 10-1/2 L/C, 8 \times 10 L/C, 7-1/2 \times 10-1/2 L/C
Power requirements	Supplied by copier
Power consumption	Less than 17 W
Dimensions	5-1/2 in. (width) \times 17-1/4 in. (depth) \times 14-1/4 in. (height)
Weight	About 6-3/4 lbs.

Duplexing Document Feeder AFR-18

Specification	
Document feed methods	Plain paper: Single-sided and double-sided documents Thick paper: Plain paper 34-1/4 to 55-3/4 lbs. “Mixed Orig Detection” function: Various sizes of single-sided and double-sided documents
Document paper type	Single-sided: 9-1/4 to 34 lbs. Double-sided or “Mixed Orig Detection” function: 13-1/4 to 29-1/4 lbs.
Document paper size	Single-sided/double-sided documents: Ledger L (11 × 17 L) to Invoice L (5-1/2 × 8-1/2 L) Mixed document sizes: Refer to Table 1.
Capacity of document feeder	Single-sided/double-sided documents: Less than 100 sheets (21-1/4 lbs.) Mixed document sizes: Less than 100 sheets (21-1/4 lbs.)
Power requirements	Supplied by copier
Power consumption	Less than 60 W
Dimensions	23 in. (width) × 20-1/2 in. (depth) × 5-1/4 in. (height) (not including the document output tray)
Weight	About 31-1/4 lbs.

Table 1: Possible combinations for mixed original paper sizes

Document width → ↓ Document sizes	11 × 17 L	8.5 × 11 C	8.5 × 14 L	8.5 × 11 L	8.5 × 5.5 C	8.5 × 5.5 L
11 × 17 L	○	○	—	—	—	—
8.5 × 11 C	○	○	—	—	—	—
8.5 × 14 L	○	○	○	○	○	—
8.5 × 11 L	○	○	○	○	○	—
8.5 × 5.5 C	—	—	○	○	○	—
8.5 × 5.5 L	—	—	—	—	—	○

○: Available

—: Not Available

Paper Feed Unit PF-118

Specification	
Paper type	Plain paper (17 to 24 lbs.)
Paper size	11 × 14 L, Ledger L (11 × 17 L), Legal L (8-1/2 × 14 L), Letter C (8-1/2 × 11 C), Letter L (8-1/2 × 11 L), 8 × 11 L/C
Paper capacity	500 sheets (21-1/4 lbs.)
Power requirements	Supplied by copier
Power consumption	Less than 15 W
Dimensions	21 in. (width) × 22-1/4 in. (depth) × 5 in. (height)
Weight	About 18-3/4 lbs.

Large Capacity Cabinet PF-121

Specification	
Paper type	Plain paper (17 to 24 lbs.)
Paper size	Letter C (8-1/2 × 11 L)
Paper capacity	2,500 sheets (21-1/4 lbs.)
Power requirements	Supplied by copier
Power consumption	Less than 45 W
Dimensions	21 in. (width) × 22-1/4 in. (depth) × 11-1/4 in. (height)
Weight	About 37-1/2 lbs.

Finisher FN-8

Specification	
Output trays	Paper output tray and lower paper output tray
Settings	Normal functions: "Non-sort", "Sort", "Sort"/"Staple" and "Saddle Staple" settings Hole-punch functions: "Non-sort"/"Punch", "Sort"/"Punch" and "Sort"/"Staple"/"Punch" settings
Paper type	Paper output tray: "Non-sort" setting: Plain paper (17 to 24 lbs.), thick paper 1 (24-1/4 to 40 lbs.), thick paper 2 (40-1/4 to 55-1/2 lbs.), thick paper 3 (55-3/4 to 68 lbs.), postcards, envelopes, label sheets, overhead projector transparency "Sort" and "Sort"/"Staple" settings: Plain paper (17 to 24 lbs.) Lower paper output tray: Plain paper (17 to 24 lbs.)

Specification	
Paper size	Paper output tray: “Non-sort” setting: Invoice L/C (5-1/2 × 8-1/2 L/C), Letter L/C (8-1/2 × 11 L/C), Legal L (8-1/2 × 14 L), Ledger L (11 × 17 L), 12-1/4 × 18 L (12 × 18 L) “Sort” setting: Letter L/C (8-1/2 × 11 L/C), Legal L (8-1/2 × 14 L), Ledger L (11 × 17 L) “Sort”/“Staple” setting: Letter L/C (8-1/2 × 11 L/C), Legal L (8-1/2 × 14 L), Ledger L (11 × 17 L) “Punch” setting: 3-hole: Letter C (8-1/2 × 11 C), Ledger L (11 × 17 L) 2-hole: Letter L/C (8-1/2 × 11 L/C), Legal L (8-1/2 × 14 L), Ledger L (11 × 17 L) Lower paper output tray: Letter L (8-1/2 × 11 L), Ledger L (11 × 17 L)
Paper capacity	Paper output tray: Plain paper (17 to 24 lbs.): 1,000 sheets of Letter L-size paper or smaller, or 500 sheets of Legal-L-size paper or large Thick paper 1, 2 and 3 (24-1/4 to 68 lbs.): Maximum 20 sheets; Postcards/envelopes/overhead projector transparencies/label sheets: Maximum 20 sheets Lower paper output tray: 10 copies (6 to 10 bound pages) 20 copies (2 to 5 bound pages)
“Staple” setting	Paper sizes (no. of bound pages): Letter L/C (8-1/2 × 11 L/C), Legal L/C (8-1/2 × 14 L/C), Ledger L/C (11 × 17 L/C) (Densely printed paper: 2 to 20 sheets)
“Punch” setting	Paper sizes: 3-hole: Letter C (8-1/2 × 11 C), Ledger L (11 × 17 L), 2-hole: Letter L/C (8-1/2 × 11 L/C), Legal L (8-1/2 × 14 L), Ledger L (11 × 17 L) Number of punched holes: 2/3
Power requirements	Supplied by copier (Punch kit: supplied by finisher)
Power consumption	Less than 65 W
Dimensions	22-3/4 in. (width) × 23-3/4 in. (depth) × 39 in. (height)
Weight	About 91-3/4 lbs. (including the horizontal transport unit)
Accessories	1 staple cartridge (5,000 staples for 50 sheets)

Finisher FN-116

Specification	
No. of bins	Non-sort tray, Elevated tray
Settings	When copying: “Non-sort” setting When printing: “Non-sort”, “Sort”, “Group” and “Staple” settings
Paper type	Non-sort tray: “Non-sort” setting: Plain paper (17 to 24 lbs.), Thick 1 (24-1/4 to 40 lbs.), Thick 2 (40-1/4 to 55-1/2 lbs.), Thick 3 (55-3/4 to 68 lbs.), overhead projector transparencies, postcards, envelopes, and label sheets Elevated tray “Sort”/“Group” settings: Plain paper (17 to 24 lbs.) “Staple” setting: Plain paper (17 to 24 lbs.)

Specification	
Paper size	<p>Non-sort tray: Invoice L/C (5-1/2 × 8-1/2 L/C), Letter L/C (8-1/2 × 11 L), Legal L (8-1/2 × 14 L), Ledger L (11 × 17 L), Executive L/C (7-1/4 × 10-1/2 L/C)</p> <p>Elevated tray: Invoice L/C (5-1/2 × 8-1/2 L/C), Letter L/C (8-1/2 × 11 L/C), Legal L (8-1/2 × 14 L), Ledger L (11 × 17 L), Executive L/C (7-1/4 × 10-1/2 L/C), 12-1/4 × 18 L (12 × 18 L)</p>
Paper capacity	<p>Non-sort tray: Plain paper (21-1/4 lbs.): Maximum 250 sheets (Invoice L/C, Letter L/C, Executive L/C, Legal L, Ledger L) Thick paper: Maximum 20 sheets Overhead projector transparencies: postcards, envelopes, label sheets: Maximum 20 sheets</p> <p>Elevated tray: Plain paper (21-1/4 lbs.): Maximum 1,000 sheets Letter L-size paper or smaller; Maximum 500 sheets Legal L-size paper or larger</p>
"Staple" setting	<p>Paper size: Letter L/C (8-1/2 × 11 L/C), Executive L/C (7-1/4 × 10-1/2 L/C), Legal L (8-1/2 × 14 L), Ledger L (11 × 17 L) Number of sheets bound: 2 to 30 sheets (2 to 20 sheets with densely printed paper)</p>
Power requirements	Supplied by copier
Power consumption	Less than 63 W
Dimensions	21-1/4 in. (width) × 25 in. (depth) × 38-1/2 in. (height)
Weight	About 84 lbs. (including the horizontal transport unit)
Accessories	1 staple cartridge (3,000 staples)

Option Tray

Specification	
Setting	Option tray
Paper type	Plain paper (17 to 24 lbs.)
Paper size	Invoice L (5-1/2 × 8-1/2 L), Letter L/C (8-1/2 × 11 L/C), Executive L/C, 7-1/4 × 10-1/2 L/C, Legal L (8-1/2 × 14 L), Ledger L (11 × 17 L)
Paper capacity	Letter C: 100 sheets, Except Letter C: 50 sheets
Dimensions	13-1/2 in. (width) × 20-3/4 in. (depth) × 5-3/4 in. (height)
Weight	About 3-3/4 lbs.

8.2 Care of the Copier

Cleaning

Set the power switch of the copier to “O” before cleaning it.

Housing cover

- Clean the surface of the housing cover by wiping it with a soft cloth dampened with a mild household detergent.

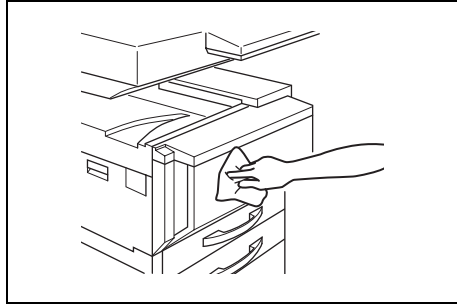

Original glass

- Clean the original glass by wiping it with a soft, dry cloth.

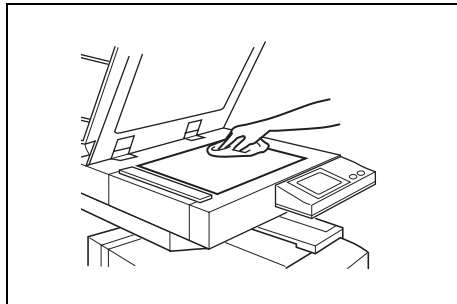

Operation panel

- Clean the operation panel by wiping it with a soft, dry cloth.



Note

Pressing too hard on the operation panel or the touch panel may damage them. In addition, never use mild household detergent or glass cleaner to clean the operation panel or touch panel.

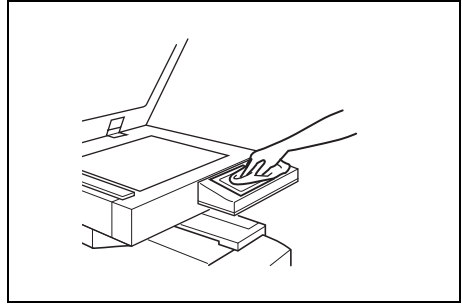

Document transfer belt

- 1 Clean the document transfer belt by wiping it with a soft cloth dampened with a mild household detergent.

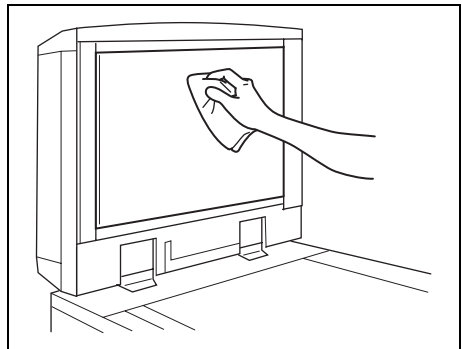

- 2 Carefully slide the belt to the left to expose a hidden area of the belt.

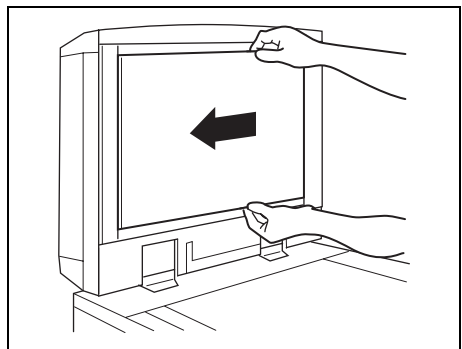

- 3 Clean the newly exposed surface of the belt by wiping it with a soft cloth dampened with a mild household detergent (as in step 1). Repeat the above steps until the entire surface of the document transfer belt has been wiped clean.

Paper take-up roller

- Clean the paper take-up roller by wiping it with a soft, dry cloth.

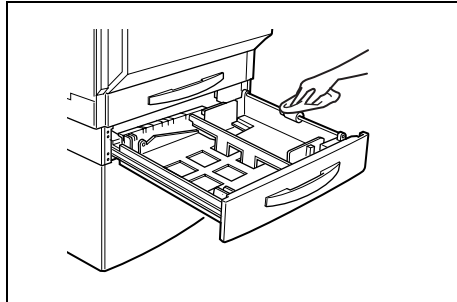
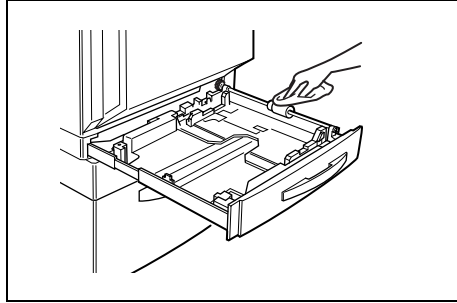

Electrostatic charger

If the Electrostatic charger is dirty, streaks will appear through the copies. If this occurs, clean the charger according to the following procedure.

- 1 Open the front door.
- 2 Slowly pull out the charger-cleaning tool as far as possible, and then slowly push in the charger-cleaning tool as much as possible. Repeat this step three times. Perform this operation with each charger-cleaning tool.

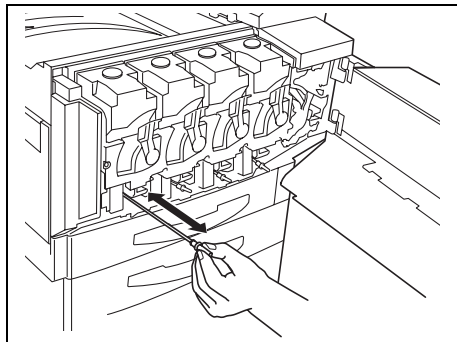

- 3 Securely insert each charger-cleaning tool, and then close the front door.

8.3 Function Combination Table

Setting selected later →	Setting selected first	Document																												
		1	2	3	4	5	6	7	8	9	10	11	12	13	14	15	16	17	18	19	20	21	22	23	24	25	26	27	28	
		Copies	Multi-Sheet Feeding	Manual Feeding	Auto Color	Full Color	Black	Auto Paper	1st Drawer	2nd Drawer /P.F.U./L.C.C.	Manual bypass tray	Standard+Double-sided	Thick Paper1	Thick Paper1+Double-sided	Thick Paper2	Thick Paper2+Double-sided	Thick Paper3	Thick Paper3+Double-sided	OHP	Envelop	High Quality Paper	Speciality Setting	Single Sided Only Setting	Auto Size	Full Size	Enlarging/Reducing	Zooming	Custom Zoom	X/Y Zoom	
1	Copies	○	○	○	○	○	○	○	○	○	○	○	○	○	○	○	○	○	○	○	○	○	○	○	○	○	○	○	○	
2	Multi-Sheet Feeding	○	○	○	○	○	○	○	○	○	○	○	○	○	○	○	○	○	○	○	○	○	○	○	○	○	○	○	○	○
3	Manual Feeding	○	○	○	○	○	○	○	○	○	○	○	○	○	○	○	○	○	○	○	○	○	○	○	○	○	○	○	○	○
4	Auto Color	○	○	○	○	○	○	○	○	○	○	○	○	○	○	○	○	○	○	○	○	○	○	○	○	○	○	○	○	○
5	Full Color	○	○	○	○	○	○	○	○	○	○	○	○	○	○	○	○	○	○	○	○	○	○	○	○	○	○	○	○	○
6	Black	○	○	○	○	○	○	○	○	○	○	○	○	○	○	○	○	○	○	○	○	○	○	○	○	○	○	○	○	○
7	Auto Paper	○	○	○	○	○	○	○	○	○	○	○	○	○	○	○	○	○	○	○	○	○	○	○	○	○	○	○	○	○
8	1st Drawer	○	○	○	○	○	○	○	○	○	○	○	○	○	○	○	○	○	○	○	○	○	○	○	○	○	○	○	○	○
9	2nd Drawer /P.F.U./L.C.C.	○	○	○	○	○	○	○	○	○	○	○	○	○	○	○	○	○	○	○	○	○	○	○	○	○	○	○	○	○
10	Manual bypass tray	○	○	○	○	○	○	○	○	○	○	○	○	○	○	○	○	○	○	○	○	○	○	○	○	○	○	○	○	○
11	Standard+Double-sided	○	○	○	○	○	○	○	○	○	○	○	○	○	○	○	○	○	○	○	○	○	○	○	○	○	○	○	○	○
12	Thick Paper1	○	○	○	○	○	○	○	○	○	○	○	○	○	○	○	○	○	○	○	○	○	○	○	○	○	○	○	○	○
13	Thick Paper1+Double-sided	○	○	○	○	○	○	○	○	○	○	○	○	○	○	○	○	○	○	○	○	○	○	○	○	○	○	○	○	○
14	Thick Paper2	○	○	○	○	○	○	○	○	○	○	○	○	○	○	○	○	○	○	○	○	○	○	○	○	○	○	○	○	○
15	Thick Paper2+Double-sided	○	○	○	○	○	○	○	○	○	○	○	○	○	○	○	○	○	○	○	○	○	○	○	○	○	○	○	○	○
16	Thick Paper3	○	○	○	○	○	○	○	○	○	○	○	○	○	○	○	○	○	○	○	○	○	○	○	○	○	○	○	○	○
17	Thick Paper3+Double-sided	○	○	○	○	○	○	○	○	○	○	○	○	○	○	○	○	○	○	○	○	○	○	○	○	○	○	○	○	○
18	OHP	○	○	○	○	○	○	○	○	○	○	○	○	○	○	○	○	○	○	○	○	○	○	○	○	○	○	○	○	○
19	Envelop	○	○	○	○	○	○	○	○	○	○	○	○	○	○	○	○	○	○	○	○	○	○	○	○	○	○	○	○	○
20	High Quality Paper	○	○	○	○	○	○	○	○	○	○	○	○	○	○	○	○	○	○	○	○	○	○	○	○	○	○	○	○	○
21	Speciality Setting	○	○	○	○	○	○	○	○	○	○	○	○	○	○	○	○	○	○	○	○	○	○	○	○	○	○	○	○	○
22	Single Sided Only Setting	○	○	○	○	○	○	○	○	○	○	○	○	○	○	○	○	○	○	○	○	○	○	○	○	○	○	○	○	○
23	Auto Size	○	○	○	○	○	○	○	○	○	○	○	○	○	○	○	○	○	○	○	○	○	○	○	○	○	○	○	○	○
24	Full Size	○	○	○	○	○	○	○	○	○	○	○	○	○	○	○	○	○	○	○	○	○	○	○	○	○	○	○	○	○
25	Enlarging/Reducing	○	○	○	○	○	○	○	○	○	○	○	○	○	○	○	○	○	○	○	○	○	○	○	○	○	○	○	○	○
26	Zooming	○	○	○	○	○	○	○	○	○	○	○	○	○	○	○	○	○	○	○	○	○	○	○	○	○	○	○	○	○
27	Custom Zoom	○	○	○	○	○	○	○	○	○	○	○	○	○	○	○	○	○	○	○	○	○	○	○	○	○	○	○	○	○
28	X/Y Zoom	○	○	○	○	○	○	○	○	○	○	○	○	○	○	○	○	○	○	○	○	○	○	○	○	○	○	○	○	○
29	Density setting	○	○	○	○	○	○	○	○	○	○	○	○	○	○	○	○	○	○	○	○	○	○	○	○	○	○	○	○	○
30	Auto background density	○	○	○	○	○	○	○	○	○	○	○	○	○	○	○	○	○	○	○	○	○	○	○	○	○	○	○	○	○
31	Background density setting	○	○	○	○	○	○	○	○	○	○	○	○	○	○	○	○	○	○	○	○	○	○	○	○	○	○	○	○	○
32	Text	○	○	○	○	○	○	○	○	○	○	○	○	○	○	○	○	○	○	○	○	○	○	○	○	○	○	○	○	○
33	Text and Photo	○	○	○	○	○	○	○	○	○	○	○	○	○	○	○	○	○	○	○	○	○	○	○	○	○	○	○	○	○
34	Map	○	○	○	○	○	○	○	○	○	○	○	○	○	○	○	○	○	○	○	○	○	○	○	○	○	○	○	○	○
35	Photo Image	○	○	○	○	○	○	○	○	○	○	○	○	○	○	○	○	○	○	○	○	○	○	○	○	○	○	○	○	○
36	Printed Image	○	○	○	○	○	○	○	○	○	○	○	○	○	○	○	○	○	○	○	○	○	○	○	○	○	○	○	○	○
37	Copied Image	○	○	○	○	○	○	○	○	○	○	○	○	○	○	○	○	○	○	○	○	○	○	○	○	○	○	○	○	○
38	Text Enhancement Setting	○	○	○	○	○	○	○	○	○	○	○	○	○	○	○	○	○	○	○	○	○	○	○	○	○	○	○	○	○
39	Dot Matrix Original	○	○	○	○	○	○	○	○	○	○	○	○	○	○	○	○	○	○	○	○	○	○	○	○	○	○	○	○	○
40	Glossy Mode	○	○	○	○	○	○	○	○	○	○	○	○	○	○	○	○	○	○	○	○	○	○	○	○	○	○	○	○	○
41	Single-sided Original	○	○	○	○	○	○	○	○	○	○	○	○	○	○	○	○	○	○	○	○	○	○	○	○	○	○	○	○	○
42	Double-sided Original	○	○	○	○	○	○	○	○	○	○	○	○	○	○	○	○	○	○	○	○	○	○	○	○	○	○	○	○	○
43	Book Separation	○	①	○	○	○	○	○	○	○	○	○	○	○	○	○	○	○	○	○	○	○	○	○	○	○	○	○	○	○
44	Book Spread	○	①	○	○	○	○	○	○	○	○	○	○	○	○	○	○	○	○	○	○	○	○	○	○	○	○	○	○	○
45	Original Direction	○	○	○	○	○	○	○	○	○	○	○	○	○	○	○	○	○	○	○	○	○	○	○	○	○	○	○	○	○
46	Margin	○	○	○	○	○	○	○	○	○	○	○	○	○	○	○	○	○	○	○	○	○	○	○	○	○	○	○	○	○
47	Single-sided Copy	○	○	○	○	○	○	○	○	○	○	○	○	○	○	○	○	○	○	○	○	○	○	○	○	○	○	○	○	○
48	Double-sided Copy	○	○	○	○	○	○	○	○	○	○	○	○	○	○	○	○	○	○	○	○	○	○	○	○	○	○	○	○	○
49	Single-sided 2in1 Copy	○	○	○	○	○	○	○	○	○	○	○	○	○	○	○	○	○	○	○	○	○	○	○	○	○	○	○	○	○

	Setting selected later →	Document		Color mode			Paper			Paper type/attribute										Zoom								
		1	2	3	4	5	6	7	8	9	10	11	12	13	14	15	16	17	18	19	20	21	22	23	24	25	26	27
← Setting selected first		Copies	Multi-Sheet Feeding	Manual Feeding	Auto Color	Full Color	Black	Auto Paper	1st Drawer	2nd Drawer / P. F. U./L. C.C.	Manual Bypass tray	Standard/Double-sided	Thick Paper1	Thick Paper2	Thick Paper2/Double-sided	Thick Paper3	Thick Paper3/Double-sided	OHP	Envelop	High Quality Paper	Specialty Setting	Single Sided Only Setting	Auto Size	Full Size	Enlarging/Reducing	Zooming	Custom Zoom	X/Y Zoom
50	Double-sided 2in1 Copy	○	○	○	○	○	○	○	○	△	⊗	⊗	⊗	⊗	⊗	⊗	⊗	⊗	⊗	○	○	⊗	○	○	○	○	○	△
51	Single-sided 4in1 Copy	○	○	○	○	○	○	○	○	△	⊗	⊗	⊗	⊗	⊗	⊗	⊗	⊗	⊗	○	○	⊗	○	○	○	○	○	△
52	Double-sided 4in1 Copy	○	○	○	○	○	○	○	○	△	⊗	⊗	⊗	⊗	⊗	⊗	⊗	⊗	⊗	○	○	⊗	○	○	○	○	○	△
53	Booklet Copy	○	○	○	○	○	○	○	○	△	⊗	⊗	⊗	⊗	⊗	⊗	⊗	⊗	⊗	○	○	⊗	○	○	○	○	○	△
54	Booklet Binding	○	○	○	○	○	○	○	○	○	○	○	○	○	○	○	○	○	○	○	○	○	○	○	○	○	○	△
55	Non-Sort	○	○	○	○	○	○	○	○	○	○	○	○	○	○	○	○	○	○	○	○	○	○	○	○	○	○	△
56	Sort	○	○	○	○	○	○	○	○	○	△	○	○	○	○	○	○	○	○	○	○	○	○	○	○	○	○	△
57	Corner Staple	○	○	○	○	○	○	○	○	○	○	○	○	○	○	○	○	○	○	○	○	○	○	○	○	○	○	△
58	2-Point Staple	○	○	○	○	○	○	○	○	○	○	○	○	○	○	○	○	○	○	○	○	○	○	○	○	○	○	△
59	Hole-punch	○	○	○	○	○	○	○	○	○	○	○	○	○	○	○	○	○	○	○	○	○	○	○	○	○	○	△
60	OHP Interleaving	▽	○	○	○	○	△	○	○	○	○	○	○	○	○	○	○	○	○	○	○	○	○	○	○	○	○	○
61	File Margin	○	○	○	○	○	○	○	○	○	○	○	○	○	○	○	○	○	○	○	○	○	○	○	○	○	○	○
62	Edge/Frame Erase	○	○	○	○	○	○	○	○	○	○	○	○	○	○	○	○	○	○	○	○	○	○	○	○	○	○	○
63	Image Repeat	○	○	○	○	○	△	○	○	○	○	○	○	○	○	○	○	○	○	○	○	○	○	○	○	○	○	○
64	Mirror Image	○	○	○	○	○	○	○	○	○	○	○	○	○	○	○	○	○	○	○	○	○	○	○	○	○	○	○
65	Distribution	○	○	○	○	○	○	○	○	○	△	○	○	○	○	○	○	○	○	○	○	○	○	○	○	○	○	○
66	Postcard	○	⊕	○	○	○	△	○	○	○	△	○	○	○	○	○	○	○	○	○	○	○	○	○	○	○	○	○
67	Multi-Page Enlargement	▽	⊕	○	○	○	○	○	○	○	△	○	○	○	○	○	○	○	○	○	○	○	○	○	○	○	○	○
68	Image Adjust	○	⊕	○	○	○	△	○	○	○	○	○	○	○	○	○	○	○	○	○	○	○	○	○	○	○	○	○
69	Monotone	○	○	○	▼	▼	▼	○	○	○	○	○	○	○	○	○	○	○	○	○	○	○	○	○	○	○	○	○
70	Background Color	○	○	○	△	△	○	○	○	○	○	○	○	○	○	○	○	○	○	○	○	○	○	○	○	○	○	○
71	Neg. Pos. Reverse	○	○	○	○	○	○	○	○	○	○	○	○	○	○	○	○	○	○	○	○	○	○	○	○	○	○	○
72	Color Separation/Black	▽	⊕	○	△	△	○	○	○	○	△	○	○	○	○	○	○	○	○	○	○	○	○	○	○	○	○	○
73	Color Separation/Each	▽	⊕	○	△	△	○	○	○	○	△	○	○	○	○	○	○	○	○	○	○	○	○	○	○	○	○	○
74	Mixed Orig Detection	○	○	○	○	○	○	○	○	○	○	○	○	○	○	○	○	○	○	○	○	○	○	○	○	○	○	○
75	Separate Scan	○	○	○	○	○	○	○	○	○	○	○	○	○	○	○	○	○	○	○	○	○	○	○	○	○	○	○
76	Interrupt	○	○	○	○	○	○	○	○	○	○	○	○	○	○	○	○	○	○	○	○	○	○	○	○	○	○	○
77	Portrait	○	○	○	○	○	○	○	○	○	○	○	○	○	○	○	○	○	○	○	○	○	○	○	○	○	○	○
78	Red	○	○	○	○	○	○	○	○	○	○	○	○	○	○	○	○	○	○	○	○	○	○	○	○	○	○	○
79	Blue	○	○	○	○	○	○	○	○	○	○	○	○	○	○	○	○	○	○	○	○	○	○	○	○	○	○	○
80	Green	○	○	○	○	○	○	○	○	○	○	○	○	○	○	○	○	○	○	○	○	○	○	○	○	○	○	○
81	Hue	○	○	○	○	○	○	○	○	○	○	○	○	○	○	○	○	○	○	○	○	○	○	○	○	○	○	○
82	Saturation	○	○	○	○	○	○	○	○	○	○	○	○	○	○	○	○	○	○	○	○	○	○	○	○	○	○	○
83	Brightness	○	○	○	○	○	○	○	○	○	○	○	○	○	○	○	○	○	○	○	○	○	○	○	○	○	○	○
84	Sharpness	○	○	○	○	○	○	○	○	○	○	○	○	○	○	○	○	○	○	○	○	○	○	○	○	○	○	○
85	Color Balance	○	○	○	○	○	○	○	○	○	○	○	○	○	○	○	○	○	○	○	○	○	○	○	○	○	○	○
86	Density	○	○	○	○	○	○	○	○	○	○	○	○	○	○	○	○	○	○	○	○	○	○	○	○	○	○	○
87	Contrast	○	○	○	○	○	○	○	○	○	○	○	○	○	○	○	○	○	○	○	○	○	○	○	○	○	○	○
88	Test Print	▽	▽	▽	▽	▽	▽	▽	▽	▽	▽	▽	▽	▽	▽	▽	▽	▽	▽	▽	▽	▽	▽	▽	▽	▽	▽	▽
89	Centering	○	○	○	○	○	○	○	○	○	○	○	○	○	○	○	○	○	○	○	○	○	○	○	○	○	○	○
90	Job Memory Input																											
91	Job Recall																											
92	Copy track																											
93	Plug-in Counter	○	○	○	○	○	○	○	○	○	○	○	○	○	○	○	○	○	○	○	○	○	○	○	○	○	○	○

		Creation										Mixed originals	Color Image Adjust																	
Setting selected later →	Setting selected first ↓	63	64	65	66	67	68	69	70	71	72	73	74	75	76	77	78	79	80	81	82	83	84	85	86	87	88	89	90	91
		Image Repeat	Mirror Image	Distribution	Postcard	Multi-Page Enlargement	Image Adjust	Monotone	Background Color	Neg. Pos. Reverse	Color Separation/Black	Color Separation/Each	Mixed Orig Detection	Separate Scan	Interrupt	Portrait	Red	Blue	Green	Hue	Saturation	Brightness	Sharpness	Color Balance	Density	Contrast	Test Print	Centering	Job Memory Input	Job Recall
50	Double-sided 2in1 Copy	▼	○	○	▼	▼	▼	○	○	○	▼	▼	△	△	—	—	—	—	—	—	—	—	—	—	—	—	—	—	—	—
51	Single-sided 4in1 Copy	▼	○	○	▼	▼	▼	○	○	○	▼	▼	△	△	—	—	—	—	—	—	—	—	—	—	—	—	—	—	—	—
52	Double-sided 4in1 Copy	▼	○	○	▼	▼	▼	○	○	○	▼	▼	△	△	—	—	—	—	—	—	—	—	—	—	—	—	—	—	—	—
53	Booklet Copy	▼	○	○	▼	▼	▼	○	○	○	▼	▼	△	△	—	—	—	—	—	—	—	—	—	—	—	—	—	—	—	—
54	Booklet Binding	▼	○	○	▼	▼	▼	○	○	○	▼	▼	△	△	—	—	—	—	—	—	—	—	—	—	—	—	—	—	—	—
55	Non-Sort	○	○	▼	○	○	○	○	○	○	○	○	○	○	—	—	—	—	—	—	—	—	—	—	—	—	—	—	—	—
56	Sort	○	○	○	▼	▼	▼	○	○	○	○	○	○	○	—	—	—	—	—	—	—	—	—	—	—	—	—	—	—	—
57	Corner Staple	▼	○	○	▼	▼	▼	○	○	○	○	○	○	○	—	—	—	—	—	—	—	—	—	—	—	—	—	—	—	—
58	2-Point Staple	▼	○	○	▼	▼	▼	○	○	○	○	○	○	○	—	—	—	—	—	—	—	—	—	—	—	—	—	—	—	—
59	Hole-punch	○	○	○	▼	▼	▼	○	○	○	○	○	○	○	—	—	—	—	—	—	—	—	—	—	—	—	—	—	—	—
60	OHP Interleaving	△	△	△	△	△	△	△	△	△	△	△	△	△	—	—	—	—	—	—	—	—	—	—	—	—	—	—	—	—
61	File Margin	▼	○	○	▼	▼	▼	○	○	○	○	○	○	○	—	—	—	—	—	—	—	—	—	—	—	—	—	—	—	—
62	Edge/Frame Erase	○	○	○	○	▼	▼	○	○	○	○	○	○	○	—	—	—	—	—	—	—	—	—	—	—	—	—	—	—	—
63	Image Repeat	△	△	△	△	△	△	△	△	△	△	△	△	△	—	—	—	—	—	—	—	—	—	—	—	—	—	—	—	—
64	Mirror Image	△	△	△	△	△	△	△	△	△	△	△	△	△	—	—	—	—	—	—	—	—	—	—	—	—	—	—	—	—
65	Distribution	△	△	△	△	△	△	△	△	△	△	△	△	△	—	—	—	—	—	—	—	—	—	—	—	—	—	—	—	—
66	Postcard	△	△	△	△	△	△	△	△	△	△	△	△	△	—	—	—	—	—	—	—	—	—	—	—	—	—	—	—	—
67	Multi-Page Enlargement	△	△	△	△	△	△	△	△	△	△	△	△	△	—	—	—	—	—	—	—	—	—	—	—	—	—	—	—	—
68	Image Adjust	△	△	△	△	△	△	△	△	△	△	△	△	△	—	—	—	—	—	—	—	—	—	—	—	—	—	—	—	—
69	Monotone	○	○	△	○	○	○	△	△	△	△	△	△	△	—	—	—	—	—	—	—	—	—	—	—	—	—	—	—	—
70	Background Color	○	○	△	○	○	○	△	△	△	△	△	△	△	—	—	—	—	—	—	—	—	—	—	—	—	—	—	—	—
71	Neg. Pos. Reverse	○	○	○	○	○	○	○	△	△	△	△	△	△	—	—	—	—	—	—	—	—	—	—	—	—	—	—	—	—
72	Color Separation/Black	△	△	△	△	△	△	△	△	△	△	△	△	△	—	—	—	—	—	—	—	—	—	—	—	—	—	—	—	—
73	Color Separation/Each	△	△	△	△	△	△	△	△	△	△	△	△	△	—	—	—	—	—	—	—	—	—	—	—	—	—	—	—	—
74	Mixed Orig Detection	△	△	△	△	△	△	△	△	△	△	△	△	△	—	—	—	—	—	—	—	—	—	—	—	—	—	—	—	—
75	Separate Scan	○	○	○	△	△	△	△	△	△	△	△	△	△	—	—	—	—	—	—	—	—	—	—	—	—	—	—	—	—
76	Interrupt	△	△	△	△	△	△	△	△	△	△	△	△	△	—	—	—	—	—	—	—	—	—	—	—	—	—	—	—	—
77	Portrait	○	○	○	○	○	○	○	○	○	○	○	○	○	—	—	—	—	—	—	—	—	—	—	—	—	—	—	—	—
78	Red	○	○	○	○	○	○	○	○	○	○	○	○	○	—	—	—	—	—	—	—	—	—	—	—	—	—	—	—	—
79	Blue	○	○	○	○	○	○	○	○	○	○	○	○	○	—	—	—	—	—	—	—	—	—	—	—	—	—	—	—	—
80	Green	○	○	○	○	○	○	○	○	○	○	○	○	○	—	—	—	—	—	—	—	—	—	—	—	—	—	—	—	—
81	Hue	○	○	○	○	○	○	○	○	○	○	○	○	○	—	—	—	—	—	—	—	—	—	—	—	—	—	—	—	—
82	Saturation	○	○	○	○	○	○	○	○	○	○	○	○	○	—	—	—	—	—	—	—	—	—	—	—	—	—	—	—	—
83	Brightness	○	○	○	○	○	○	○	○	○	○	○	○	○	—	—	—	—	—	—	—	—	—	—	—	—	—	—	—	—
84	Sharpness	○	○	○	○	○	○	○	○	○	○	○	○	○	—	—	—	—	—	—	—	—	—	—	—	—	—	—	—	—
85	Color Balance	○	○	○	○	○	○	○	○	○	○	○	○	○	—	—	—	—	—	—	—	—	—	—	—	—	—	—	—	—
86	Density	○	○	○	○	○	○	○	○	○	○	○	○	○	—	—	—	—	—	—	—	—	—	—	—	—	—	—	—	—
87	Contrast	○	○	○	○	○	○	○	○	○	○	○	○	○	—	—	—	—	—	—	—	—	—	—	—	—	—	—	—	—
88	Test Print	▼	▼	▼	▼	▼	▼	▼	▼	▼	▼	▼	▼	▼	—	—	—	—	—	—	—	—	—	—	—	—	—	—	—	—
89	Centering	※	○	○	※	※	※	○	○	○	○	○	○	○	—	—	—	—	—	—	—	—	—	—	—	—	—	—	—	—
90	Job Memory Input	—	—	—	—	—	—	—	—	—	—	—	—	—	—	—	—	—	—	—	—	—	—	—	—	—	—	—	—	—
91	Job Recall	—	—	—	—	—	—	—	—	—	—	—	—	—	—	—	—	—	—	—	—	—	—	—	—	—	—	—	—	—
92	Copy track	○	○	○	○	○	○	○	○	○	○	○	○	○	—	—	—	—	—	—	—	—	—	—	—	—	—	—	—	—
93	Plug-in Counter	○	○	○	○	○	○	○	○	○	○	○	○	○	—	—	—	—	—	—	—	—	—	—	—	—	—	—	—	—

Function Combination Table

Function combination code keys

- : The functions can be combined.
 - ▼: The functions cannot be combined. The function set last has priority.
 - △: The functions cannot be combined. The function set first has priority.
A warning message will appear.
 - ▽: The functions cannot be combined. The function set first has priority.
No warning message will appear, or other functions will not be available after the first function is selected.
 - : The functions cannot be combined.
- ①: The functions can be combined only when the document is fed manually.
A warning message will appear.
 - ②: If paper is loaded through the manual bypass tray, a warning message appears that the functions cannot be combined. If paper is not to be loaded through the manual bypass tray, de-select it as the paper source.
 - ③: If paper is loaded through the manual bypass tray, copying cannot be interrupted.
 - ④: A warning message appears that the manual bypass tray should be selected as the paper source. Previously selected settings will be canceled when paper is loaded.
 - ⑤: The “Mixed Orig Detection” function cannot be used when making “single-sided ► double-sided” copies.
 - ⑥: The functions cannot be combined depending on the finisher model.
 - ⑦: The “Original Direction” and “Margin” functions can be set, but their settings are not highlighted.
 - ⑧: A message appears, warning that the paper is unsuitable for double-sided printing.
 - ⑨: The settings for the “Dot Matrix Original” parameter (39) and the “Text Enhancement” function (38) do not affect printing. For example, set the “Text Enhancement” function (38) to “+3 (Darker)” while the “Text” setting (32) is selected. Then, if the Photo/Density setting “Photo Image” (35) is selected, the “Text Enhancement” setting of “+3 (Darker)” will not affect the printing. The settings for the “Dot Matrix Original” parameter (39) and the “Text Enhancement” function (38) are maintained, even if all modes and function are returned to their default settings using the “Auto Panel Reset” function. For example, set the “Text Enhancement” function (38) to “+3 (Darker)” while the “Text” setting (32) is selected. Then, select a Photo/Density setting that the

Text Enhancement setting has no effect on, such as “Photo Image”.

Next, select a Photo/Density setting where the Text Enhancement setting can be specified, such as the “Text” setting (32) or the “Map” setting (34). The previously specified Text Enhancement setting of “+3 (Darker)” is maintained.

✖: The “Centering” function from the Utility mode can be set, but will not be applied.

Number of First Setting	Number of Next Setting	Description
1	57, 58	Number of copies: If the entered number of copies exceeds the number allowable for the “Non-sort” and “stapling” settings, a message warning that the number of copies for stapling has been exceeded. If the warning is ignored and the job is started, the “stapling” setting is canceled.
57, 58	1	
4	77 ~ 82, 85	Color setting “Auto Color” The functions cannot be combined with the Color setting “Auto Color”. However, if the Color setting “Auto Color” determines that the Color setting “Black” should be used, printing continues without the setting for the Color image Adjust parameters applied.
77 ~ 82, 85	4	
40	12 ~19	1st drawer (multipurpose paper drawer): The functions cannot be combined if a paper size that cannot be loaded into the 1st drawer is selected.
48, 50, 52, 53, 54	11~19	A message appears, warning that the 1st drawer is selected and the paper type was changed.
23, 27	67	“Multi-Page Enlargement” function: The zoom ratio specified for the “Multi-Page Enlargement” function is applied.
67	23, 27	“Multi-Page Enlargement” function: A zoom ratio cannot be specified.
74	63, 68	“Mixed Orig Detection” function: The function can be selected, but the setting is not applied.
63, 68	74	
57, 58	76	Interrupt mode: With the stapling on finisher FN-8, printing is interrupted between copy sets.
67	76	Interrupt mode: The job cannot be interrupted while scanning for the “Multi-Page Enlargement” function.
63, 66, 67, 68	89	“Centering” function: The function can be selected, but the setting is not applied.
89	63, 66, 67, 68	
90	11~19	“Job Memory Input” function: A program using the 1st drawer cannot be stored.
All	All	Test prints: Another function cannot be selected while a test print is being printed. When a test print is printed, the mode returns to the one before the test print was performed. The paper drawer is selected according to the priority order.

8.4 Paper Size and Zoom Ratio Tables

Paper Sizes

Paper Format	Metric Size	English Size
A3 Wide	311 mm × 457 mm	12-1/4 in. × 18 in.
A3	297 mm × 420 mm	11-3/4 in. × 16-1/2 in.
A4	210 mm × 297 mm	8-1/4 in. × 11-3/4 in.
A5	148 mm × 210 mm	5-3/4 in. × 8-1/4 in.
A6	105 mm × 148 mm	4-1/4 in. × 5-3/4 in.
B4	257 mm × 364 mm	10 in. × 14-1/4 in.
B5	182 mm × 257 mm	7-1/4 in. × 10 in.
B6	128 mm × 182 mm	5 in. × 7-1/4 in.

Paper Format		English Size	Metric Size
Ledger		11 in. × 17 in.	279 mm × 432 mm
11 in. × 14 in.		11 in. × 14 in.	279 mm × 356 mm
Computer		10-1/8 in. × 14 in.	257 mm × 356 mm
10 in. × 14 in.		10 in. × 14 in.	254 mm × 356 mm
9-1/4 in. × 14 in.		9-1/4 in. × 14 in.	236 mm × 356 mm
Legal		8-1/2 in. × 14 in.	216 mm × 356 mm
Foolscap	Government Legal	8-1/2 in. × 13 in.	216 mm × 330 mm
Foolscap		8 in. × 13 in.	203 mm × 330 mm
Foolscap		8-2/3 in. × 13 in.	220 mm × 330 mm
Foolscap	Folio	8-1/4 in. × 13 in.	210 mm × 330 mm
8-1/4 in. × 11-3/4 in.		8-1/4 in. × 11-3/4 in.	210 mm × 301 mm
Letter		8-1/2 in. × 11 in.	216 mm × 279 mm
Government Letter		8 in. × 10-1/2 in.	203 mm × 267 mm
Quarto		8 in. × 10 in.	203 mm × 254 mm
Statement	Invoice	5-1/2 in. × 8-1/2 in.	140 mm × 216 mm
4 in. × 6 in.		4 in. × 6 in.	102 mm × 152 mm

Zoom Ratios

Metric Sizes		
Document Paper Size	Desired Paper Size	Zoom Ratio
A3 297 mm × 420 mm 11-3/4 in. × 16-1/2 in.	A4	× 0.707
	A5	× 0.500
	B4	× 0.866
	B5	× 0.610
A4 210 mm × 297 mm 8-1/4 in. × 11-3/4 in.	A5	× 0.707
	A6	× 0.500
	B5	× 0.866
	B6	× 0.610
	A3	× 1.414
A5 148 mm × 210 mm 5-3/4 in. × 8-1/4 in.	B4	× 1.224
	A6	× 0.707
	B6	× 0.866
	A4	× 1.414
	A3	× 2.000
A6 105 mm × 148 mm 4-1/4 in. × 5-3/4 in.	B4	× 1.733
	B5	× 1.224
	A4	× 2.000
	A5	× 1.414
	B6	× 1.733
B4 257 mm × 364 mm 10 in. × 14-1/4 in.	B5	× 1.224
	A4	× 0.816
	A5	× 0.577
	B5	× 0.707
	B6	× 0.500
B5 182 mm × 257 mm 7-1/4 in. × 10 in.	A3	× 1.154
	A5	× 0.816
	A6	× 0.577
	B6	× 0.707
	A3	× 1.640
	A4	× 1.154
B4	× 1.414	

B6 128 mm × 182 mm 5 in. × 7-1/4 in.	A6	× 0.816
	A4	× 1.640
	A5	× 1.154
	B4	× 2.000
	B5	× 1.414

English Sizes		
Document Paper Size	Desired Paper Size	Zoom Ratio
Ledger 11 in. × 17 in. 279.4 mm × 431.8 mm	11 in. × 14 in.	× 0.823
	Legal	× 0.722
	Foolscap	× 0.764
	Letter	× 0.647
	Invoice	× 0.500
11 in. × 15 in. 279.4 mm × 381 mm	11 in. × 14 in.	× 0.933
	Legal	× 0.772
	Foolscap	× 0.772
	Letter	× 0.733
	Invoice	× 0.500
11 in. × 14 in. 279.4 mm × 355.6 mm	Legal	× 0.772
	Foolscap	× 0.772
	Letter	× 0.772
	Invoice	× 0.500
Legal 8-1/2 in. × 14 in. 215.9 mm × 355.6 mm	Foolscap	× 0.928
	Letter	× 0.785
	Invoice	× 0.607
	11 in. × 17 in.	× 1.214
Foolscap 8-1/2 in. × 13 in. 215.9 mm × 330.2 mm	Letter	× 0.846
	Invoice	× 0.647
	11 in. × 17 in.	× 1.294
	11 in. × 14 in.	× 1.076
Letter 8-1/2 in. × 11 in. 215.9 mm × 279.4 mm	Invoice	× 0.647
	11 in. × 17 in.	× 1.294
	11 in. × 14 in.	× 1.272

Invoice 5-1/2 in. × 8-1/2 in. 139.7 mm × 215.9 mm	11 in. × 17 in.	× 2.000
	11 in. × 14 in.	× 1.647
	Legal	× 1.545
	Foolscap	× 1.529
	Letter	× 1.294

Zoom ratio = Paper size/Document size

1 in. (inch) = 25.4 mm

1 mm = 0.0394 in. (inch)

8.5 Consumables

In order to maintain the condition of this machine, the following consumables are needed.

For best copy quality, we recommend that the specified supplies be used.

For information on or for purchasing supplies, contact your nearest technical representative.

Paper

In addition to plain paper, thick paper, A3 Wide paper and overhead projector transparencies are also available.



Note

In order to protect unwrapped paper from humidity, keep it in a plastic bag and stored in a cool, dark location.

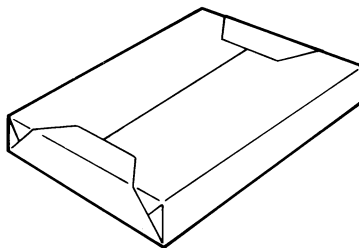

Toner Cartridges

Cartridges for cyan, magenta, yellow and black toner are available.



Note

Only use toner that has been manufactured specifically for this copier.

Do not throw away the used toner cartridges. Instead, keep them in their boxes to be collected by your service representative.

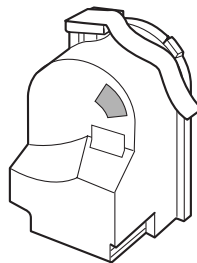

Staple Cartridges

FN-116

Staples for staple binding

3,000 staples are provided in the staple cartridge.

FN-8

Staples for staple binding

5,000 staples are provided in the staple cartridge.

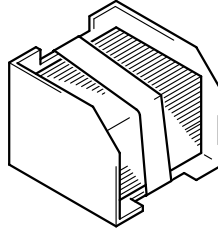

Index

9

9.1 Index

Numerics

1st drawer	4-5
2in1, 4in1, booklet copy zoom	5-28
2nd drawer	4-5
4in1 copy order	5-30

A

ACS judgement level adjust.	5-27
Adjust the color shifts	5-42
Administrator access code	5-35
Administrator mode	5-35
Auto clear mode	5-19
Auto panel reset	5-16
Auto-select paper for small original	5-29

C

Care of the copier	8-8
Center binding position	5-54
Centering	5-31
Confirmation beep	5-10
Control panel	4-6
Copier	4-2
Copier stand	4-3
Copy desk	4-2
Copy program	5-5, 5-6
Copy table	4-3
Copy track	5-60
Criss cross mode	5-25

D

Date/time set	5-11
Default settings	5-7
Disable sleep mode	5-37
Duplex unit	4-3, 4-10
Duplexing document feeder	4-2, 4-10, 8-4
Dust remover	4-8

E

Energy saver	5-17
Expert mode	5-40

F

Filter	4-8
Finisher (FN-116)	4-2, 4-12
Finisher (FN-8)	4-3, 4-11
Front door	4-5
Function combination table	8-11
Fusing unit	4-8

G

Gradation adjust	5-56
------------------------	------

H

Hard disk	4-4
-----------------	-----

I

Image transfer belt unit	4-8
Image transfer roller unit	4-8
Imaging unit	4-8
Initial mode	5-4
Input	5-3
Installation site	3-2
Intelligent sorting	5-24

L

Landscape	1-5
Language selected	5-39
Large capacity cabinet	4-2, 4-12
LED-cleaning tool	4-8
Legal restrictions on copying	3-7
Lower right-side door	4-5

M

Manual bypass tray	4-5
Media type selection dial	4-6
Memory	4-4
Memory recall	5-13
Meter count	5-32
Monochrome image density correct	5-46

O

Operation precautions	3-4
Option tray	4-2, 4-12, 8-7
Original cover	4-3
Output tray priority	5-23
Over size paper selection	5-38
Ozone filter	4-8

P

Paper feed unit	4-3, 4-10
Paper feeding	1-4
Paper misfeed clearing	6-17
Duplex unit	6-21
Duplexing document feeder	6-31
Finisher FN-116	6-35
Finisher FN-8	6-39
Large capacity cabinet	6-24
Manual bypass tray	6-19
Paper drawer	6-22
Right-side door	6-25
Upper right-side door	6-28
Paper orientation	1-5

Paper sizes	8-19
Portrait	1-5
Power source	3-2
Printer controller	4-4
Priority device	5-26
PRT area	5-47
Dup. left margin	5-52
Left margin	5-50
Top margin	5-47
Punch kit	4-4
Punch scraps	6-52

R

Reset mode	5-4
------------------	-----

S

Scanner	4-2
Sleep	5-18
Space requirements	3-3
Specialty paper	5-22
Specialty paper settings	5-21
Specifications	8-2
Stabilizer	5-58
Staple cartridge replacement	
FN-116	6-10
FN-8	6-12
Staple jam clearing	
FN-116	6-43
FN-8	6-45

T

Thick paper and OHP film image density	5-41
Toner cartridge	4-8
Toner cartridges	8-23
Top erase	5-36
Troubleshooting	7-2

U

Unit life indicator	5-34
Upper right-side door	4-9
User's choice: 1	5-7
User's choice: 2	5-9
Utility	5-2

W

Waste-toner bottle	4-8
--------------------------	-----

Z

Zoom ratios	8-20
-------------------	------



MINOLTA

Copyright
2002 MINOLTA CO., LTD.

The information contained in this manual is subject to change without notice to incorporate improvements made on the product or products the manual covers.